

A Technical Guide to the Biochemical Properties of DOTA-Tyr3-Octreotate

Author: BenchChem Technical Support Team. **Date:** December 2025

Compound of Interest

Compound Name: Tyr3-Octreotate

Cat. No.: B15623244

[Get Quote](#)

For Researchers, Scientists, and Drug Development Professionals

This in-depth technical guide provides a comprehensive overview of the core biochemical properties of DOTA-Tyr3-Octreotate (DOTA-TATE), a key radiopharmaceutical agent in the diagnosis and treatment of neuroendocrine tumors. This document details its binding characteristics, cellular interactions, and stability, supported by established experimental protocols and visual representations of key biological and experimental processes.

Quantitative Biochemical Data

The following tables summarize the key quantitative parameters of DOTA-TATE, facilitating a comparative analysis of its biochemical behavior.

Table 1: Receptor Binding Affinity of DOTA-TATE Analogs

Compound	Receptor Subtype	Kd (nM)	IC50 (nM)	Cell Line/Tissue	Reference
⁶⁷ Ga-DOTA-TATE	sst2	0.45 ± 0.11	-	Rat brain cortex membranes	[1]
¹⁷⁷ Lu-DOTA-TATE	SSTR2	0.08 ± 0.02	-	HEK-SSTR2 cells	[2]
natGa-DOTA-TATE	sstr2	-	0.20 ± 0.18	AR42J cells	[3]
natSc-DOTA-TATE	sstr2	-	0.70 ± 0.20	AR42J cells	[3]
Cu-DOTA-Y3-TATE	-	-	1.78	AR42J tumor membranes	[4]
La ³⁺ -DOTA-TATE	SSTR2	-	19.00 ± 9.2 (Ki)	HEK293/SSTR2 cells	[5]

Kd: Dissociation Constant; IC50: Half-maximal Inhibitory Concentration. Ki: Inhibitory Constant.

Table 2: Kinetic and Stability Parameters of DOTA-TATE

Parameter	Value	Conditions	Reference
Dissociation Rate (koff)	Biphasic dissociation	In the presence of excess unlabeled agonist	[2]
In Vitro Stability (177Lu-DOTA-TATE)	>97% intact	Human plasma, 24 hours	[6]
In Vivo Stability (177Lu-DOTA-TATE)	23% ± 5% intact	Human plasma, 24 hours post-injection	[7]
In Vitro Stability (177Lu-DOTA-TATE)	91.4% intact	Acetate buffer, 312 hours	[6]

Experimental Protocols

Detailed methodologies for the key experiments cited are provided below to facilitate reproducibility and further research.

Radiolabeling of DOTA-TATE with ^{68}Ga

This protocol outlines the automated synthesis of ^{68}Ga -DOTA-TATE for PET imaging.

Materials:

- $^{68}\text{Ge}/^{68}\text{Ga}$ generator
- Automated labeling module
- DOTA-TATE peptide
- HEPES buffer (1.5 M)
- Sterile vials
- Vented and non-vented sterile filters (0.2 μm)
- Lead shielding

Procedure:

- Place the ^{68}Ga labeling kit on the automated module according to the manufacturer's instructions.
- Attach the sterile solutions provided in the kit to the manifolds.
- Place a vented 0.2 μm filter in a sterile collection vial.
- Attach the sterile vial with a non-vented filter to the output of the labeling module and place it in a lead shield.
- Connect the output of the ^{68}Ga generator to the input of the labeling module.

- Dissolve the DOTA-TATE peptide (typically 20-50 μg) in 1.5 mL of 1.5 M HEPES buffer and transfer it to the reaction vial.[8]
- Initiate the automated synthesis of ^{68}Ga -DOTA-TATE via the attached computer.
- Upon completion, perform quality control to assess radiochemical purity using instant thin-layer chromatography and solid-phase chromatography.[9]

Saturation Binding Assay for K_d Determination

This assay determines the equilibrium dissociation constant (K_d) and the maximum number of binding sites (B_{max}).

Materials:

- SSTR2-expressing cells (e.g., HEK-SSTR2) or cell membrane preparations.
- Radiolabeled DOTA-TATE (e.g., ^{177}Lu -DOTA-TATE).
- Unlabeled DOTA-TATE.
- Binding buffer (e.g., 20 mM HEPES, pH 7.4, with MgCl_2 , BSA, and protease inhibitors).[2]
- 96-well plates.
- Gamma counter.

Procedure:

- Prepare serial dilutions of the radiolabeled DOTA-TATE in binding buffer.
- In a 96-well plate, add increasing concentrations of the radioligand to wells containing a fixed amount of cell homogenate or intact cells.[10][11]
- For non-specific binding determination, add a high concentration of unlabeled DOTA-TATE (e.g., 1 μM) to a parallel set of wells.[10]
- Incubate the plate at 37°C for a sufficient time to reach equilibrium (e.g., 60 minutes).[10][11]

- Terminate the binding by rapid filtration through glass fiber filters, followed by washing with ice-cold buffer to remove unbound radioligand.
- Measure the radioactivity retained on the filters using a gamma counter.
- Calculate specific binding by subtracting non-specific binding from total binding.
- Analyze the data using non-linear regression to a one-site binding model to determine K_d and B_{max} .^[2]

Competitive Binding Assay for IC50 Determination

This assay measures the concentration of an unlabeled ligand that displaces 50% of a specifically bound radioligand.

Materials:

- SSTR2-expressing cells (e.g., AR42J) or cell membrane preparations.
- A fixed concentration of a suitable radioligand (e.g., ^{125}I -Tyr¹¹-SST-14).^[3]
- Serial dilutions of unlabeled DOTA-TATE.
- Binding buffer.
- 96-well plates.
- Gamma counter.

Procedure:

- Prepare serial dilutions of unlabeled DOTA-TATE in binding buffer.
- In a 96-well plate, add the fixed concentration of the radioligand to all wells.
- Add the serial dilutions of unlabeled DOTA-TATE to the wells.
- Add the cell membrane preparation to each well to initiate the binding reaction.

- Incubate the plate to allow the binding to reach equilibrium.
- Separate bound from free radioligand by filtration.
- Measure the radioactivity of the bound fraction.
- Plot the percentage of specific binding against the logarithm of the competitor concentration and fit the data to a sigmoidal dose-response curve to determine the IC50 value.

Cellular Internalization and Efflux Assay

This assay quantifies the rate and extent of radioligand internalization into and efflux from target cells.

Materials:

- SSTR2-expressing cells (e.g., HEK-SSTR2).
- Radiolabeled DOTA-TATE (e.g., ¹⁷⁷Lu-DOTA-TATE).
- Cell culture medium.
- Acid wash buffer (e.g., glycine-HCl, pH 2.5) to differentiate between surface-bound and internalized radioactivity.
- Cell lysis buffer (e.g., 1 M NaOH).
- Gamma counter.

Procedure for Internalization:

- Seed cells in multi-well plates and allow them to adhere.
- Incubate the cells with a fixed concentration of radiolabeled DOTA-TATE at 37°C for various time points (e.g., 0.5, 1, 2, 4 hours).
- At each time point, stop the internalization by placing the plates on ice and washing the cells with ice-cold PBS.

- To measure surface-bound radioactivity, incubate the cells with acid wash buffer on ice and collect the supernatant.
- To measure internalized radioactivity, lyse the cells with cell lysis buffer.
- Measure the radioactivity in the acid wash and the cell lysate fractions using a gamma counter.

Procedure for Efflux:

- Incubate the cells with the radioligand for a time sufficient for internalization (e.g., 2 hours at 37°C).
- Wash the cells with ice-cold PBS to remove unbound radioligand.
- Add fresh, pre-warmed medium to the cells and incubate at 37°C for various time points.
- At each time point, collect the medium (representing the effluxed radioactivity) and lyse the cells (representing the retained radioactivity).
- Measure the radioactivity in both fractions.

In Vitro Stability Study in Human Serum

This protocol assesses the stability of the radiolabeled compound in a biologically relevant matrix.

Materials:

- Radiolabeled DOTA-TATE.
- Freshly thawed human serum.
- Incubator at 37°C.
- Analytical method to separate intact radiopharmaceutical from its metabolites (e.g., HPLC).

Procedure:

- Add a known amount of radiolabeled DOTA-TATE to human serum.
- Incubate the mixture at 37°C.
- At various time points (e.g., 0.5, 4, 24, 96 hours), take aliquots of the serum.[7]
- Precipitate the serum proteins (e.g., with ethanol or acetonitrile).
- Centrifuge to pellet the precipitated proteins.
- Analyze the supernatant by radio-HPLC to determine the percentage of intact radiopharmaceutical.[7]

Visualization of Pathways and Workflows

The following diagrams, created using the DOT language, illustrate key biological and experimental processes related to DOTA-TATE.

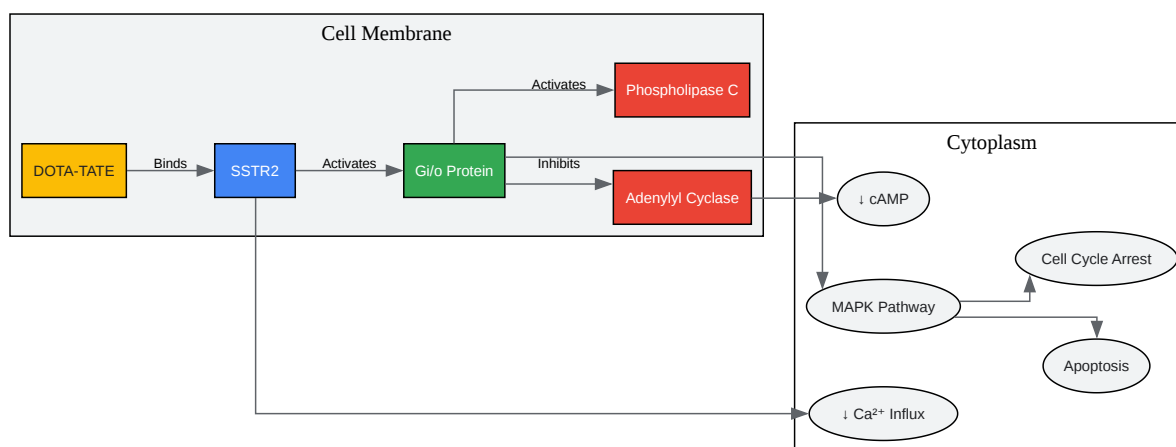

[Click to download full resolution via product page](#)

SSTR2 Signaling Pathway upon DOTA-TATE Binding.

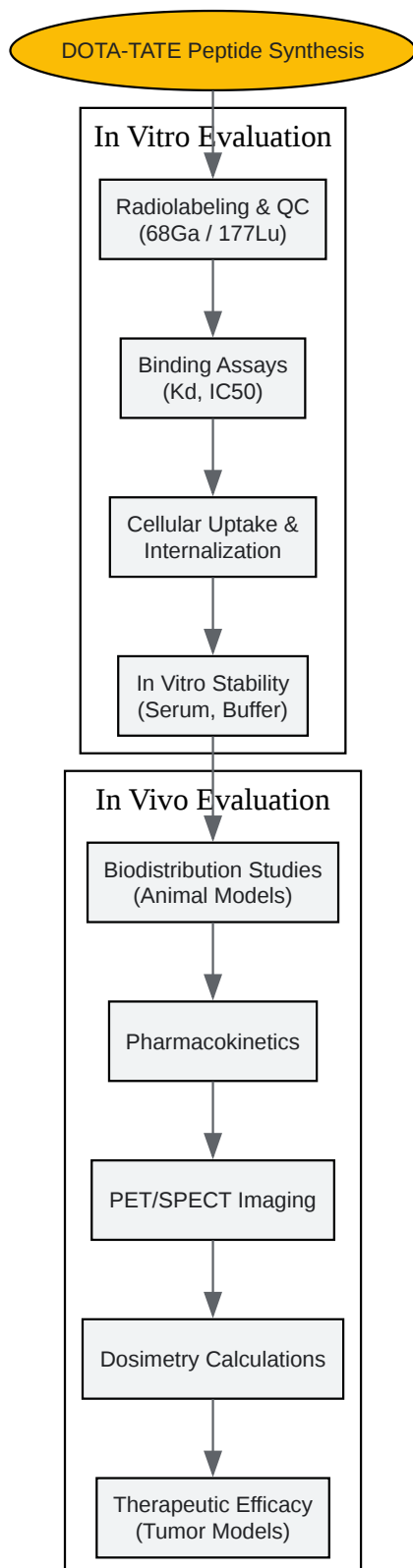

[Click to download full resolution via product page](#)

Preclinical Evaluation Workflow for DOTA-TATE.

Need Custom Synthesis?

BenchChem offers custom synthesis for rare earth carbides and specific isotopic labeling.

Email: info@benchchem.com or [Request Quote Online](#).

References

- 1. researchgate.net [researchgate.net]
- 2. Distinct In Vitro Binding Profile of the Somatostatin Receptor Subtype 2 Antagonist [177Lu]Lu-OPS201 Compared to the Agonist [177Lu]Lu-DOTA-TATE - PMC [pmc.ncbi.nlm.nih.gov]
- 3. Comparison of receptor affinity of natSc-DOTA-TATE versus natGa-DOTA-TATE - PubMed [pubmed.ncbi.nlm.nih.gov]
- 4. researchgate.net [researchgate.net]
- 5. researchgate.net [researchgate.net]
- 6. researchgate.net [researchgate.net]
- 7. In Vivo Instability of 177Lu-DOTATATE During Peptide Receptor Radionuclide Therapy - PMC [pmc.ncbi.nlm.nih.gov]
- 8. Somatostatin Receptor 2 signaling promotes growth and tumor survival in Small Cell Lung Cancer - PMC [pmc.ncbi.nlm.nih.gov]
- 9. researchgate.net [researchgate.net]
- 10. pubs.acs.org [pubs.acs.org]
- 11. Comparative Saturation Binding Analysis of 64Cu-Labeled Somatostatin Analogues Using Cell Homogenates and Intact Cells - PMC [pmc.ncbi.nlm.nih.gov]
- To cite this document: BenchChem. [A Technical Guide to the Biochemical Properties of DOTA-Tyr3-Octreotate]. BenchChem, [2025]. [Online PDF]. Available at: [https://www.benchchem.com/product/b15623244#biochemical-properties-of-dota-tyr3-octreotate]

Disclaimer & Data Validity:

The information provided in this document is for Research Use Only (RUO) and is strictly not intended for diagnostic or therapeutic procedures. While BenchChem strives to provide accurate protocols, we make no warranties, express or implied, regarding the fitness of this product for every specific experimental setup.

Technical Support: The protocols provided are for reference purposes. Unsure if this reagent suits your experiment? [[Contact our Ph.D. Support Team for a compatibility check](#)]

Need Industrial/Bulk Grade? [Request Custom Synthesis Quote](#)

BenchChem

Our mission is to be the trusted global source of essential and advanced chemicals, empowering scientists and researchers to drive progress in science and industry.

Contact

Address: 3281 E Guasti Rd
Ontario, CA 91761, United States
Phone: (601) 213-4426
Email: info@benchchem.com