

# A Technical Guide to Phenotypic Screening for Novel Antitrypanosomal Agents

**Author:** BenchChem Technical Support Team. **Date:** December 2025

## Compound of Interest

Compound Name: *Antitrypanosomal agent 16*

Cat. No.: *B12363515*

[Get Quote](#)

Audience: Researchers, Scientists, and Drug Development Professionals

This guide provides an in-depth overview of the core principles, experimental methodologies, and strategic workflows involved in phenotypic screening for the discovery of new drugs against trypanosomal parasites, the causative agents of Chagas disease (*Trypanosoma cruzi*) and Human African Trypanosomiasis (*Trypanosoma brucei*).

## Introduction: The Case for Phenotypic Screening

The search for new, effective, and safe drugs for neglected tropical diseases like Chagas disease and Human African Trypanosomiasis (HAT) is a global health priority.[1] Current treatments are often limited by toxicity, variable efficacy, and emerging resistance.[2][3] While target-based drug discovery has its merits, phenotypic screening—the testing of compounds in whole-cell or whole-organism assays—has proven to be a particularly powerful and successful strategy for identifying novel antitrypanosomal agents.[4][5] This approach assesses the ability of a compound to produce a desired phenotype (e.g., parasite death or growth inhibition) without a priori knowledge of the molecular target, offering an unbiased route to discovering new mechanisms of action.[5][6]

The drug discovery pipeline for antitrypanosomatids is notoriously slow and has a high attrition rate, making robust and efficient screening cascades essential.[4] This guide details the components of a modern phenotypic screening workflow, from high-throughput primary screens to hit validation and target deconvolution.

# The Antitrypanosomal Phenotypic Screening Workflow

A typical phenotypic screening campaign is a multi-stage process designed to efficiently identify and prioritize promising compounds from large chemical libraries. The process begins with a large-scale primary screen to identify "hits," which are then subjected to a series of increasingly stringent secondary assays to confirm activity, assess selectivity, and characterize the mode of action before advancing to in vivo studies.<sup>[1][7]</sup>

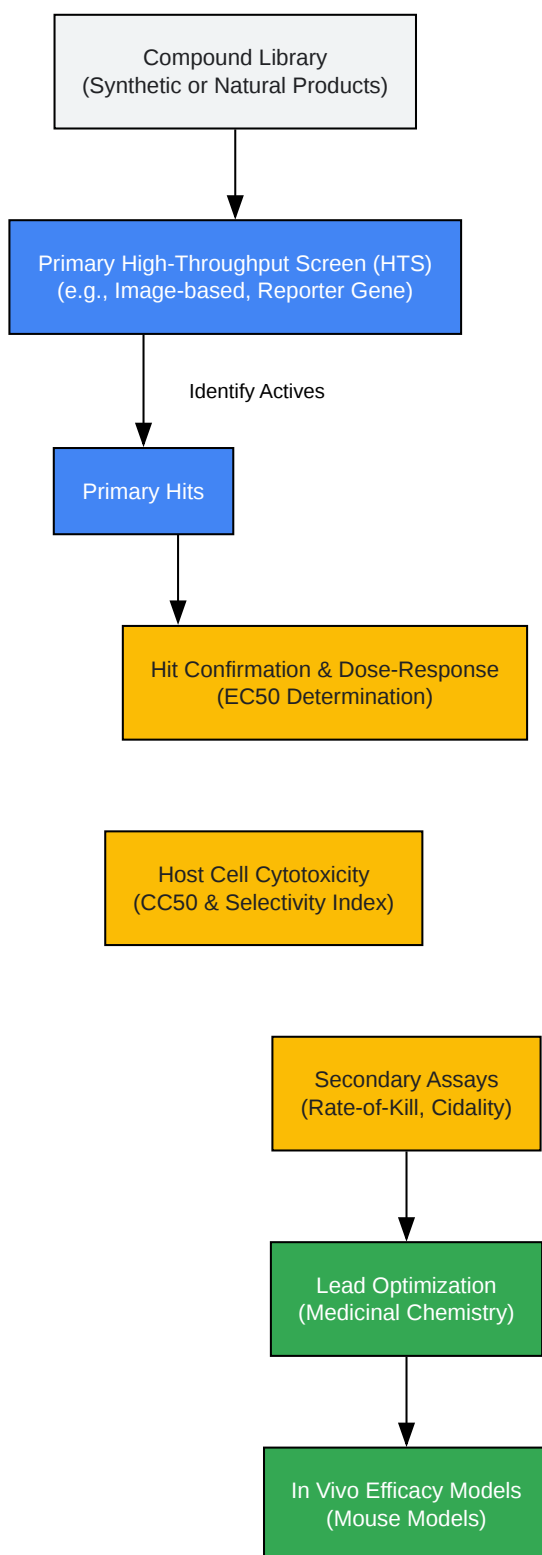

[Click to download full resolution via product page](#)

**Caption:** A generalized workflow for antitrypanosomal phenotypic drug discovery.

## Data Presentation: Summary of Screening Campaigns

Phenotypic screens have successfully identified numerous antitrypanosomal hits from diverse chemical libraries. The efficiency and output of these campaigns vary based on the library size, parasite species, and assay technology used.

Parasite Species & Stage	Library Size	Screening Concentration	Primary Hit Rate (%)	Hit Criteria / Notes	Reference(s)
Trypanosoma cruzi (intracellular amastigote)	303,224 (NIH library)	Not specified	1.45%	4,394 hits identified. 3,005 compounds had IC50 <10 µM and >10-fold selectivity.	[8]
Trypanosoma cruzi (intracellular amastigote)	>900 (FDA-approved drugs)	Not specified	~6.1%	55 active compounds identified using an image-based assay.	[8][9]
Trypanosoma cruzi (amastigote)	456 (Ty-Box)	50 µM	11%	48 primary hits with >40% antiparasitic activity.	[10]
Trypanosoma brucei (bloodstream form)	700,000	3.6 µM	0.6%	3,889 primary hits with >50% inhibition.	[11]
T. brucei, L. infantum, T. cruzi	5,976 (microbial extracts)	Not specified	Not specified	Screened against all three kinetoplastids to find broad-spectrum hits.	[3]

## Experimental Protocols

Detailed and robust protocols are critical for the success of a screening campaign. Below are methodologies for key assays in the screening cascade.

### Primary Screen: Image-Based Assay for Intracellular *T. cruzi*

This high-content screening (HCS) assay is a gold standard for identifying compounds active against the clinically relevant intracellular stage of *T. cruzi*. It simultaneously measures parasite inhibition and host cell toxicity.<sup>[9][12]</sup>

- Objective: To quantify the reduction in intracellular *T. cruzi* amastigotes in the presence of test compounds.
- Materials:
  - Host cells (e.g., Vero, U2OS, or 3T3 fibroblasts).<sup>[5][7][10]</sup>
  - *T. cruzi* trypomastigotes (e.g., Silvio X10/7 or Tulahuen strain).<sup>[5][7]</sup>
  - Assay medium (e.g., RPMI or DMEM with 2% FBS).
  - 384-well clear-bottom imaging plates.
  - Test compounds dissolved in DMSO.
  - Fixative (e.g., 4% paraformaldehyde).
  - Nuclear stain (e.g., DAPI or Hoechst 33342).<sup>[9]</sup>
  - High-content imaging system and analysis software.
- Methodology:
  - Cell Seeding: Seed host cells into 384-well plates at a density that results in a sub-confluent monolayer after 24 hours. Incubate at 37°C, 5% CO<sub>2</sub>.

- Infection: Add *T. cruzi* trypomastigotes to the host cell monolayer at a multiplicity of infection (MOI) of ~5-10. Allow parasites to invade for 2-24 hours.[5]
- Compound Addition: Wash plates to remove non-invaded trypomastigotes. Add fresh medium containing test compounds at the desired final concentration (e.g., 10-50  $\mu\text{M}$ ).[10] Include positive (e.g., benznidazole) and negative (e.g., 0.5% DMSO) controls.
- Incubation: Incubate plates for 48-72 hours to allow for parasite replication.[10]
- Fixation and Staining: Aspirate the medium, fix the cells, and permeabilize them. Stain with a nuclear dye like DAPI, which stains both the host cell nucleus and the smaller, more intense parasite kinetoplast DNA.[9]
- Imaging: Acquire images using an automated high-content microscope. Capture at least two channels (e.g., DAPI for nuclei/kinetoplasts).
- Image Analysis: Use an automated image analysis algorithm to identify and count host cell nuclei and parasite kinetoplasts. The primary readout is the number of parasites per host cell. A reduction in this ratio indicates compound efficacy, while a reduction in the host cell count indicates cytotoxicity.[9]

## Primary Screen: *T. brucei* Bloodstream Form Viability Assay

This assay is used for high-throughput screening against the bloodstream form of *T. brucei*, the stage responsible for HAT.

- Objective: To measure the inhibition of *T. brucei* growth/viability.
- Materials:
  - *Trypanosoma brucei brucei* bloodstream forms (e.g., Lister 427).[11]
  - HMI-9 medium.
  - 1536-well plates.[11]

- Test compounds in DMSO.
- Viability reagent (e.g., CellTiter-Glo, which measures ATP, or resazurin-based reagents).  
[\[11\]](#)
- Methodology:
  - Parasite Culture: Culture *T. brucei* bloodstream forms in HMI-9 medium at 37°C, 5% CO<sub>2</sub>.
  - Assay Setup: Dispense parasites into 1536-well plates at a low starting density in a small volume of medium.
  - Compound Addition: Add test compounds to a final concentration (e.g., 3.6 μM) and a final DMSO concentration of <0.5%.[\[11\]](#)
  - Incubation: Incubate plates for 48 hours.[\[11\]](#)
  - Readout: Add the viability reagent (e.g., CellTiter-Glo) and incubate as per the manufacturer's instructions. Measure luminescence or fluorescence using a plate reader.
  - Analysis: Calculate the percent inhibition of parasite growth relative to negative (DMSO) and positive (e.g., pentamidine) controls.

## Secondary Assay: Rate-of-Kill (RoK) Analysis

Standard endpoint assays provide potency data (EC<sub>50</sub>) but little information on the pharmacodynamics of a compound. RoK assays determine how quickly a compound kills the parasite, which is critical for predicting in vivo efficacy and designing dosing regimens.[\[13\]](#)

- Objective: To measure the speed of parasite clearance upon compound exposure.
- Methodology (Live-Imaging Based):
  - Assay Setup: Prepare a *T. cruzi*-infected host cell culture in a 384-well imaging plate as described in the primary assay protocol. Use parasites expressing a fluorescent reporter (e.g., GFP) for easier tracking.



- Compound Treatment: Add compounds at concentrations relative to their EC50 (e.g., 1x, 3x, 10x EC50).
- Live-Cell Imaging: Place the plate in an environmentally controlled high-content imager (37°C, 5% CO<sub>2</sub>). Acquire images of the same fields of view at regular intervals (e.g., every 3-6 hours) over a period of 72-96 hours.[13]
- Data Analysis: Quantify the fluorescent parasite signal in each well over time. Plot the signal versus time for each compound concentration to generate kill curves. This high-resolution data can distinguish between fast-acting cidal compounds and slow-acting or static compounds.[13]

## From Hit to Lead: Target Deconvolution

A major challenge in phenotypic screening is identifying the molecular target(s) of a validated hit, a process known as target deconvolution.[14] Elucidating the mechanism of action is crucial for lead optimization and for understanding potential resistance mechanisms.[4]

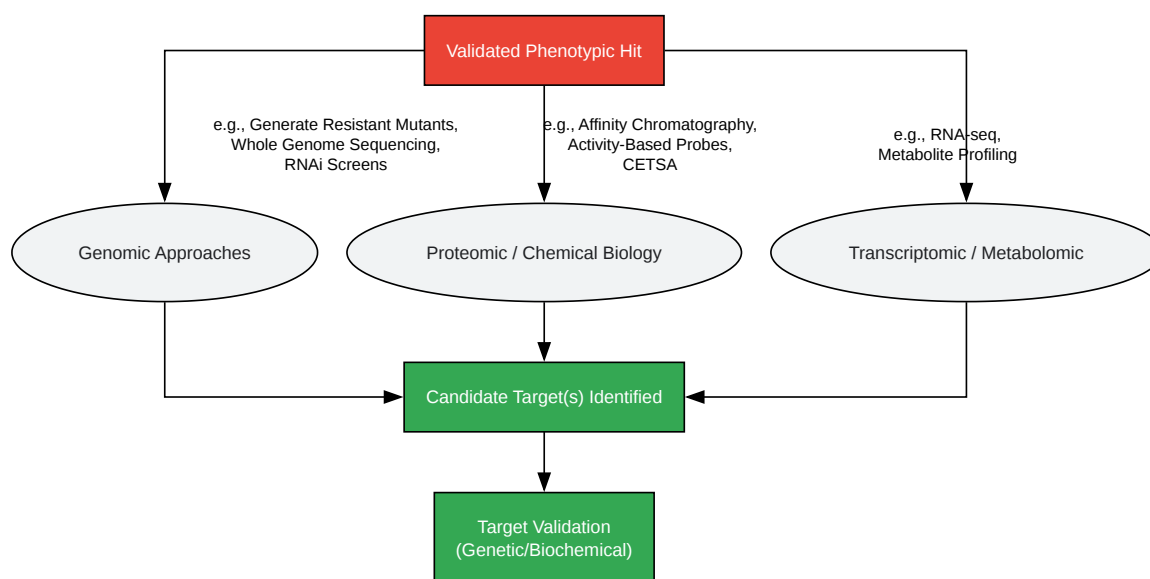

[Click to download full resolution via product page](#)

**Caption:** Key methodologies for target deconvolution of phenotypic screening hits.

One of the most powerful genetic approaches involves generating compound-resistant parasite lines followed by whole-genome sequencing to identify mutations associated with the resistance phenotype.[4] For *T. brucei*, genome-scale RNA interference (RNAi) library screens have been used to identify genes that, when knocked down, confer resistance, thereby implicating those gene products in the drug's mechanism of action or uptake pathway.[15][16]

## Relevant Biological Pathways: Drug Uptake Mechanisms

Understanding how compounds enter the parasite is fundamental, as selective uptake can be a key determinant of a drug's therapeutic window.[17] For example, genome-scale screening in *T.*

brucei revealed that the uptake of the drug suramin is mediated by a specific surface protein, ISG75, and involves the endosomal/lysosomal system.[15][18]

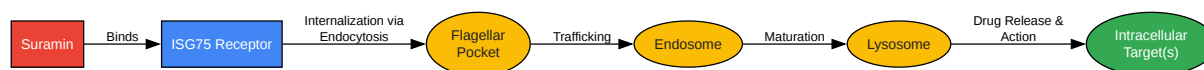

[Click to download full resolution via product page](#)

**Caption:** Proposed pathway for suramin uptake in *T. brucei* via ISG75.[15][16]

This discovery highlights how phenotypic approaches can uncover novel biology. A compound that requires an active, parasite-specific uptake mechanism is an attractive starting point, as this provides an inherent layer of selectivity against the host.

## Conclusion

Phenotypic screening remains a cornerstone of antitrypanosomal drug discovery, consistently delivering novel chemical matter with whole-organism activity.[5][19] Advances in high-content imaging, automation, and live-cell analysis are providing deeper insights into compound pharmacodynamics earlier in the discovery cascade.[12][13] The primary challenge remains the efficient deconvolution of a hit's mechanism of action. Integrating modern 'omics' and chemical biology approaches into the screening workflow is essential to overcome this bottleneck and translate promising phenotypic hits into the next generation of antitrypanosomal drugs.

### Need Custom Synthesis?

BenchChem offers custom synthesis for rare earth carbides and specific isotopic labeling.

Email: [info@benchchem.com](mailto:info@benchchem.com) or [Request Quote Online](#).

## References

- 1. Phenotypic screening approaches for Chagas disease drug discovery - PubMed [pubmed.ncbi.nlm.nih.gov]
- 2. discovery.dundee.ac.uk [discovery.dundee.ac.uk]
- 3. High-throughput screening platform for natural product-based drug discovery against 3 neglected tropical diseases: human African trypanosomiasis, leishmaniasis, and Chagas disease - PubMed [pubmed.ncbi.nlm.nih.gov]
- 4. Antitrypanosomatid drug discovery: an ongoing challenge and a continuing need - PMC [pmc.ncbi.nlm.nih.gov]
- 5. pubs.acs.org [pubs.acs.org]
- 6. High-throughput decoding of drug targets and drug resistance mechanisms in African trypanosomes | Parasitology | Cambridge Core [cambridge.org]
- 7. Development of Trypanosoma cruzi in vitro assays to identify compounds suitable for progression in Chagas' disease drug discovery | PLOS Neglected Tropical Diseases [journals.plos.org]
- 8. High Throughput Screening for Anti-Trypanosoma cruzi Drug Discovery - PMC [pmc.ncbi.nlm.nih.gov]
- 9. Image-based high-throughput drug screening targeting the intracellular stage of Trypanosoma cruzi, the agent of Chagas' disease - PubMed [pubmed.ncbi.nlm.nih.gov]
- 10. pubs.acs.org [pubs.acs.org]
- 11. mdpi.com [mdpi.com]
- 12. Past and future of trypanosomatids high-throughput phenotypic screening - PMC [pmc.ncbi.nlm.nih.gov]
- 13. Live-imaging rate-of-kill compound profiling for Chagas disease drug discovery with a new automated high-content assay | PLOS Neglected Tropical Diseases [journals.plos.org]
- 14. criver.com [criver.com]
- 15. High-throughput decoding of anti-trypanosomal drug efficacy and resistance - PMC [pmc.ncbi.nlm.nih.gov]
- 16. researchgate.net [researchgate.net]
- 17. Insights into antitrypanosomal drug mode-of-action from cytology-based profiling - PMC [pmc.ncbi.nlm.nih.gov]
- 18. High-throughput decoding of antitrypanosomal drug efficacy and resistance - Research - Institut Pasteur [research.pasteur.fr]

- 19. Phenotypic Drug Discovery for Human African Trypanosomiasis: A Powerful Approach - PubMed [pubmed.ncbi.nlm.nih.gov]
- To cite this document: BenchChem. [A Technical Guide to Phenotypic Screening for Novel Antitrypanosomal Agents]. BenchChem, [2025]. [Online PDF]. Available at: [https://www.benchchem.com/product/b12363515#phenotypic-screening-for-new-antitrypanosomal-hits]

---

### Disclaimer & Data Validity:

The information provided in this document is for Research Use Only (RUO) and is strictly not intended for diagnostic or therapeutic procedures. While BenchChem strives to provide accurate protocols, we make no warranties, express or implied, regarding the fitness of this product for every specific experimental setup.

**Technical Support:** The protocols provided are for reference purposes. Unsure if this reagent suits your experiment? [[Contact our Ph.D. Support Team for a compatibility check](#)]

**Need Industrial/Bulk Grade?** [Request Custom Synthesis Quote](#)

## BenchChem

Our mission is to be the trusted global source of essential and advanced chemicals, empowering scientists and researchers to drive progress in science and industry.

### Contact

Address: 3281 E Guasti Rd  
Ontario, CA 91761, United States  
Phone: (601) 213-4426  
Email: [info@benchchem.com](mailto:info@benchchem.com)