

A Technical Guide to Fully Mixed PTP1B Inhibitors

Author: BenchChem Technical Support Team. **Date:** December 2025

Compound of Interest

Compound Name: *Ptp1B-IN-18*

Cat. No.: *B14889392*

[Get Quote](#)

Protein Tyrosine Phosphatase 1B (PTP1B) has emerged as a critical negative regulator in key metabolic signaling pathways, making it a prominent therapeutic target for type 2 diabetes, obesity, and cancer.[1][2] Inhibitors of PTP1B offer a promising strategy to enhance insulin and leptin sensitivity. Among the various types of enzyme inhibitors, the "fully mixed" inhibitor presents a unique kinetic profile with significant implications for drug design and efficacy.

This technical guide provides an in-depth exploration of fully mixed PTP1B inhibitors, detailing their mechanism of action, the experimental protocols for their characterization, and a summary of known compounds. The content is tailored for researchers, scientists, and drug development professionals in the field.

Understanding Fully Mixed Inhibition

In enzyme kinetics, inhibition types are classified based on how the inhibitor interacts with the enzyme and the enzyme-substrate complex. A mixed inhibitor is one that can bind to both the free enzyme (E) and the enzyme-substrate (ES) complex.[3][4] The term "fully mixed" is used to describe the general case of mixed inhibition where the inhibitor's binding affinity for the free enzyme is different from its affinity for the enzyme-substrate complex.

This dual binding capability distinguishes it from:

- **Competitive Inhibition:** The inhibitor binds only to the free enzyme's active site.
- **Uncompetitive Inhibition:** The inhibitor binds only to the enzyme-substrate complex.

- Non-competitive Inhibition: A special case of mixed inhibition where the inhibitor has equal affinity for both the free enzyme and the enzyme-substrate complex.[3]

The hallmark of a fully mixed inhibitor is its effect on the enzyme's kinetic parameters: it decreases the maximum reaction velocity (V_{max}) and can either increase or decrease the substrate's apparent affinity for the enzyme (K_m), depending on its preference for binding to E versus ES.[5]

Mechanism of Mixed Inhibition

The kinetic scheme for mixed inhibition involves two distinct dissociation constants:

- K_i : The dissociation constant for the enzyme-inhibitor (EI) complex.
- K_i' (or K_{IS}): The dissociation constant for the enzyme-substrate-inhibitor (ESI) complex.

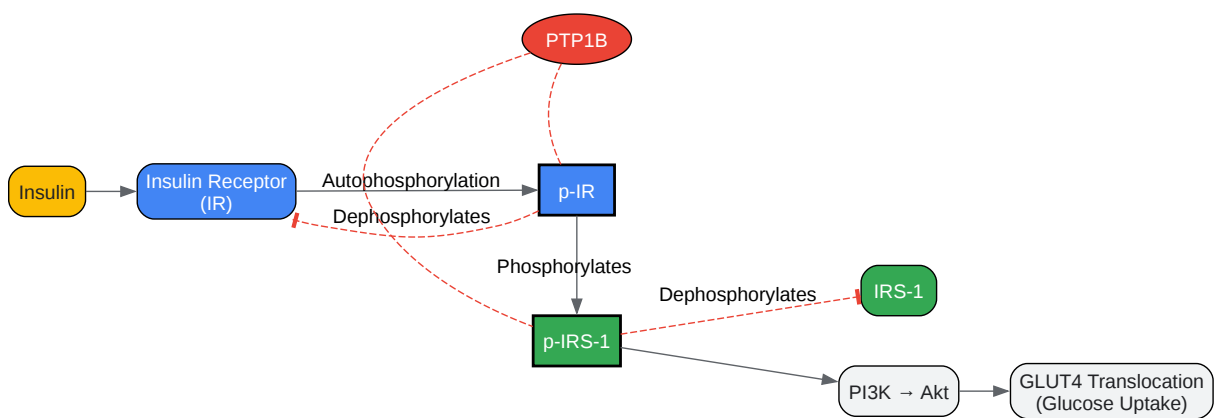
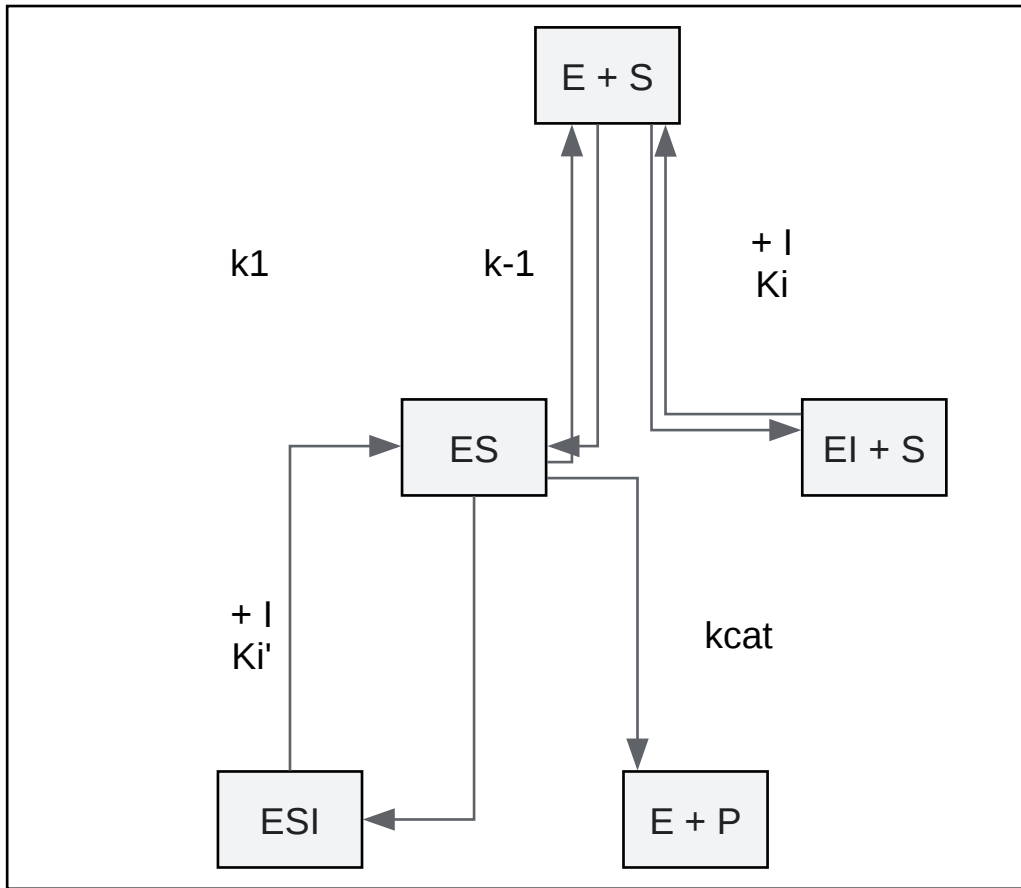

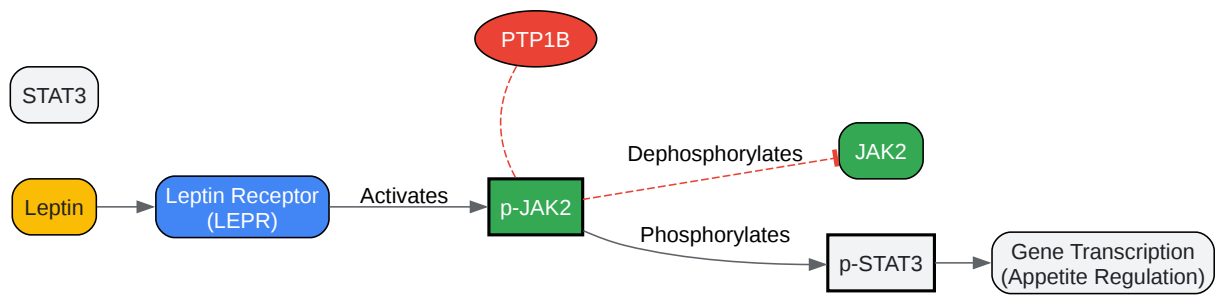

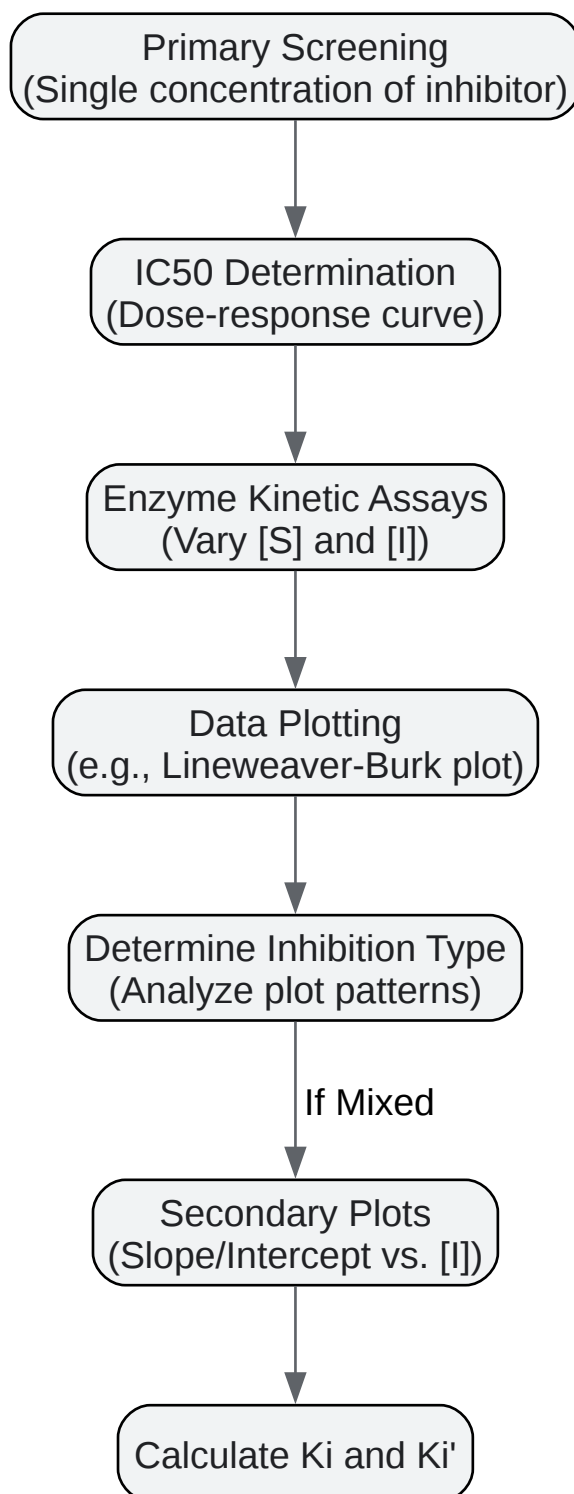

[Click to download full resolution via product page](#)

Need Custom Synthesis?

BenchChem offers custom synthesis for rare earth carbides and specific isotopic labeling.

Email: info@benchchem.com or [Request Quote Online](#).

References

- 1. bpsbioscience.com [bpsbioscience.com]
- 2. Natural products possessing protein tyrosine phosphatase 1B (PTP1B) inhibitory activity found in the last decades - PMC [pmc.ncbi.nlm.nih.gov]
- 3. Mixed inhibition - Wikipedia [en.wikipedia.org]
- 4. Mixed inhibition [unacademy.com]
- 5. medschoolcoach.com [medschoolcoach.com]
- To cite this document: BenchChem. [A Technical Guide to Fully Mixed PTP1B Inhibitors]. BenchChem, [2025]. [Online PDF]. Available at: [https://www.benchchem.com/product/b14889392#what-is-a-fully-mixed-ptp1b-inhibitor]

Disclaimer & Data Validity:

The information provided in this document is for Research Use Only (RUO) and is strictly not intended for diagnostic or therapeutic procedures. While BenchChem strives to provide accurate protocols, we make no warranties, express or implied, regarding the fitness of this product for every specific experimental setup.

Technical Support: The protocols provided are for reference purposes. Unsure if this reagent suits your experiment? [[Contact our Ph.D. Support Team for a compatibility check](#)]

Need Industrial/Bulk Grade? [Request Custom Synthesis Quote](#)

BenchChem

Our mission is to be the trusted global source of essential and advanced chemicals, empowering scientists and researchers to drive progress in science and industry.

Contact

Address: 3281 E Guasti Rd

Ontario, CA 91761, United States

Phone: (601) 213-4426

Email: info@benchchem.com