

A Technical Guide to Conjugated Estrogen Sodium Signaling Pathways in Neuronal Cells

Author: BenchChem Technical Support Team. **Date:** December 2025

Compound of Interest

Compound Name: *Conjugated Estrogen sodium*

Cat. No.: *B15541981*

[Get Quote](#)

For Researchers, Scientists, and Drug Development Professionals

Introduction

Conjugated estrogen sodium, a complex mixture of equine-derived estrogens, has long been utilized in hormone replacement therapy. Beyond its classical endocrine roles, emerging evidence highlights its significant impact on the central nervous system, particularly in neuronal cells. This technical guide provides an in-depth exploration of the core signaling pathways activated by conjugated estrogens in neurons, with a focus on their neuroprotective and neuromodulatory effects. Understanding these intricate molecular mechanisms is paramount for the development of novel therapeutic strategies for neurodegenerative diseases and cognitive decline.

This document details the principal signaling cascades initiated by conjugated estrogens, presents quantitative data on their effects, and provides comprehensive experimental protocols for key assays used to investigate these pathways.

Core Signaling Pathways of Conjugated Estrogens in Neuronal Cells

Conjugated estrogens elicit a spectrum of responses in neuronal cells through both genomic and non-genomic signaling pathways. These pathways are primarily initiated by the binding of estrogenic compounds to three key receptors: Estrogen Receptor Alpha (ER α), Estrogen

Receptor Beta (ER β), and the G-protein coupled Estrogen Receptor (GPER). While ER α and ER β are classically known as nuclear receptors that modulate gene transcription, they are also found at the plasma membrane, where they can initiate rapid, non-genomic signaling cascades.[1] GPER is a seven-transmembrane receptor that exclusively mediates rapid, non-genomic effects.[2]

Membrane-Initiated Rapid Signaling

Rapid, non-genomic signaling occurs within seconds to minutes of estrogen exposure and does not require gene transcription.[3] These pathways are crucial for the acute modulation of neuronal excitability and synaptic function.

The Mitogen-Activated Protein Kinase (MAPK)/Extracellular signal-Regulated Kinase (ERK) pathway is a central cascade in neuronal survival and plasticity. Upon binding of estrogens to membrane-associated ER α , ER β , or GPER, a series of phosphorylation events is triggered, leading to the activation of ERK1/2.[4] Activated ERK can then translocate to the nucleus to phosphorylate transcription factors, thereby influencing gene expression indirectly, or it can phosphorylate cytoplasmic targets to rapidly alter neuronal function.[4] Studies have shown that 17 β -estradiol can induce ERK phosphorylation within 5 to 15 minutes in cortical neurons.[4]

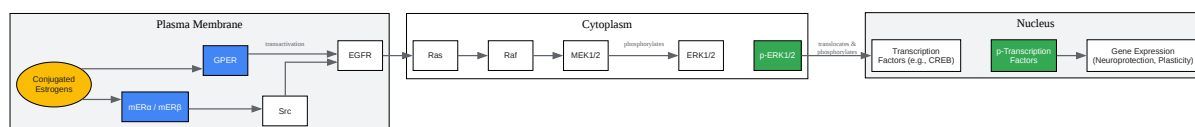

[Click to download full resolution via product page](#)

Caption: MAPK/ERK Signaling Pathway.

The Phosphoinositide 3-Kinase (PI3K)/Akt pathway is another critical pro-survival pathway in neurons. Estrogen binding to membrane receptors can lead to the activation of PI3K, which in

turn phosphorylates and activates Akt (also known as Protein Kinase B).[5] Activated Akt promotes neuronal survival by phosphorylating and inhibiting pro-apoptotic proteins such as GSK3 β and activating transcription factors that upregulate anti-apoptotic genes like Bcl-2.[6] Time-course studies have demonstrated that 17 β -estradiol can induce Akt phosphorylation within 5 minutes of exposure in cortical neurons.[7]

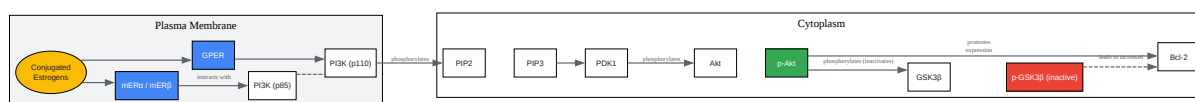

[Click to download full resolution via product page](#)

Caption: PI3K/Akt Signaling Pathway.

GPER activation by estrogens leads to the stimulation of adenylyl cyclase, resulting in increased intracellular cyclic AMP (cAMP) levels and subsequent activation of Protein Kinase A (PKA). PKA can then phosphorylate various downstream targets, including the transcription factor CREB (cAMP response element-binding protein), which is involved in learning, memory, and neuronal survival. GPER can also couple to G α_q to activate phospholipase C (PLC), leading to the generation of inositol trisphosphate (IP3) and diacylglycerol (DAG), which mobilize intracellular calcium and activate Protein Kinase C (PKC), respectively.

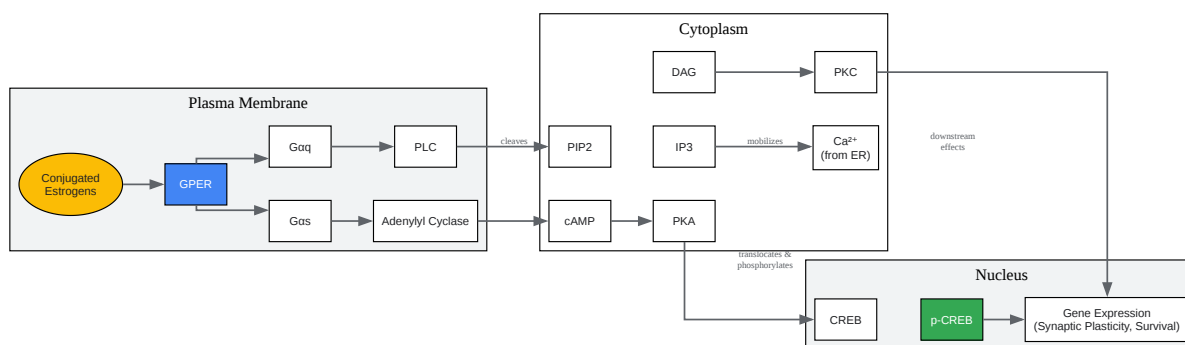

[Click to download full resolution via product page](#)

Caption: GPER-Mediated Signaling Pathways.

Genomic Signaling

The classical genomic pathway involves the binding of estrogens to nuclear ER α and ER β . This binding induces a conformational change in the receptor, leading to its dimerization and translocation to the nucleus. In the nucleus, the estrogen-receptor complex binds to specific DNA sequences known as Estrogen Response Elements (EREs) in the promoter regions of target genes, thereby regulating their transcription. This process typically occurs over hours to days and results in long-lasting changes in neuronal structure and function. Genes regulated by this pathway are involved in neuroprotection (e.g., Bcl-2), neurotransmitter synthesis, and synaptic plasticity.

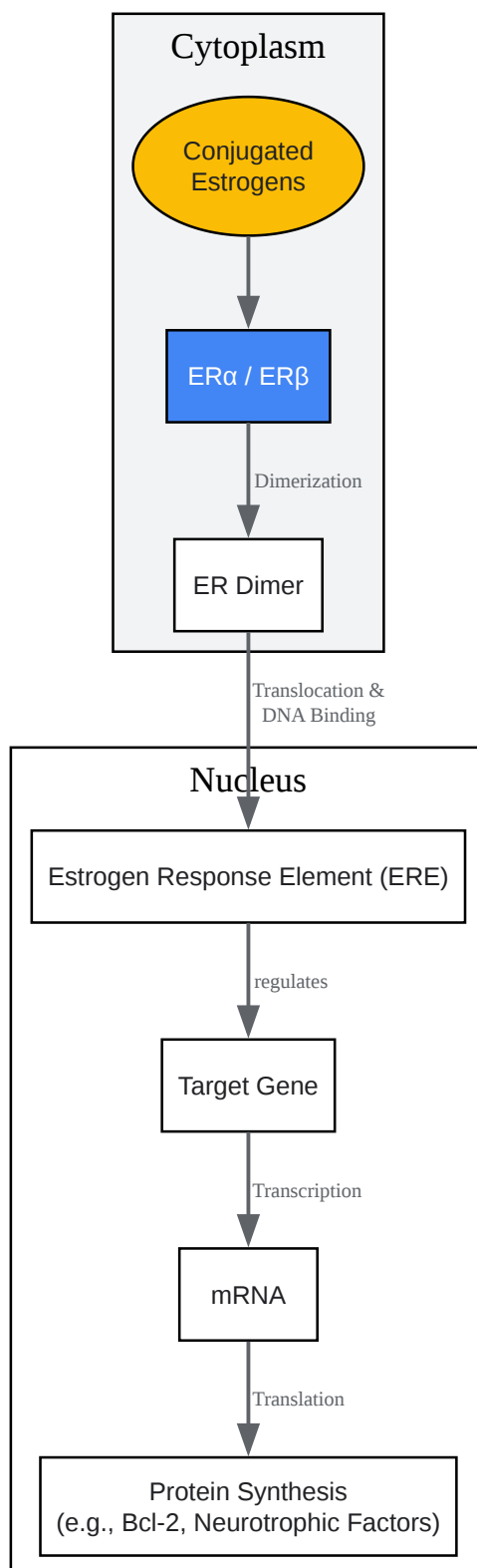

[Click to download full resolution via product page](#)

Caption: Genomic Estrogen Signaling Pathway.

Data Presentation

The following tables summarize the available quantitative data on the binding affinities of key conjugated estrogen components and their effects on neuronal signaling and viability.

Table 1: Relative Binding Affinities (RBA) of Conjugated Estrogen Components to Estrogen Receptors

| Estrogen Component | ER α RBA (%) | ER β RBA (%) | GPER Binding Affinity (K _i , nM) |
|--------------------------------|---------------------|--------------------|---|
| 17 β -Estradiol | 100 | 100 | 3-6 |
| Estrone (E1) | 10-20 | 5-10 | >10,000 |
| Equilin | 13 | 1.8 | Not Reported |
| 17 α -Estradiol | 1-5 | 1-5 | Not Reported |
| 17 α -Dihydroequilin | 12 | 1.5 | Not Reported |
| 17 β -Dihydroequilin | 25 | 3.5 | Not Reported |
| $\Delta^{8,9}$ -Dehydroestrone | 4 | 0.5 | Not Reported |
| Equilenin | 2 | 0.3 | Not Reported |
| 17 α -Dihydroequilenin | 2 | 0.2 | Not Reported |
| 17 β -Dihydroequilenin | 4 | 0.4 | Not Reported |

Data compiled from multiple sources. RBA is relative to 17 β -Estradiol (set at 100%). GPER binding affinity is presented as the inhibitor constant (K_i).

Table 2: Dose-Dependent Neuroprotective Effects of Conjugated Estrogens Against Glutamate Excitotoxicity in Primary Basal Forebrain Neurons

| Estrogen Component | Concentration (nM) | % Neuroprotection (LDH Release) |
|-------------------------------|--------------------|---------------------------------|
| 17 β -Estradiol | 10 | ~50% |
| Equilin | 10 | ~45% |
| 17 α -Estradiol | 10 | ~40% |
| 17 α -Dihydroequilin | 10 | ~35% |
| Equilenin | 10 | ~30% |
| 17 α -Dihydroequilenin | 10 | ~25% |
| 17 β -Dihydroequilenin | 10 | ~20% |
| $\Delta^8,^9$ -Dehydroestrone | 10 | ~30% |

Data estimated from graphical representations in published literature.

Table 3: Time-Course of 17 β -Estradiol (10 nM) Induced Phosphorylation of ERK1/2 and Akt in Rat Cortical Neurons

| Time (minutes) | p-ERK1/2 (% of control) | p-Akt (% of control) |
|----------------|-------------------------|----------------------|
| 0 | 100 | 100 |
| 5 | ~250 | ~200 |
| 15 | ~400 | ~300 |
| 30 | ~500 | ~250 |
| 60 | ~300 | ~150 |

Data estimated from graphical representations in published literature.[7]

Experimental Protocols

Detailed methodologies for key experiments cited in the investigation of conjugated estrogen signaling pathways are provided below.

Primary Neuronal Cell Culture and Estrogen Treatment

This protocol describes the isolation and culture of primary hippocampal neurons from embryonic day 18 (E18) rat fetuses, a common model for studying neuronal responses to estrogens.

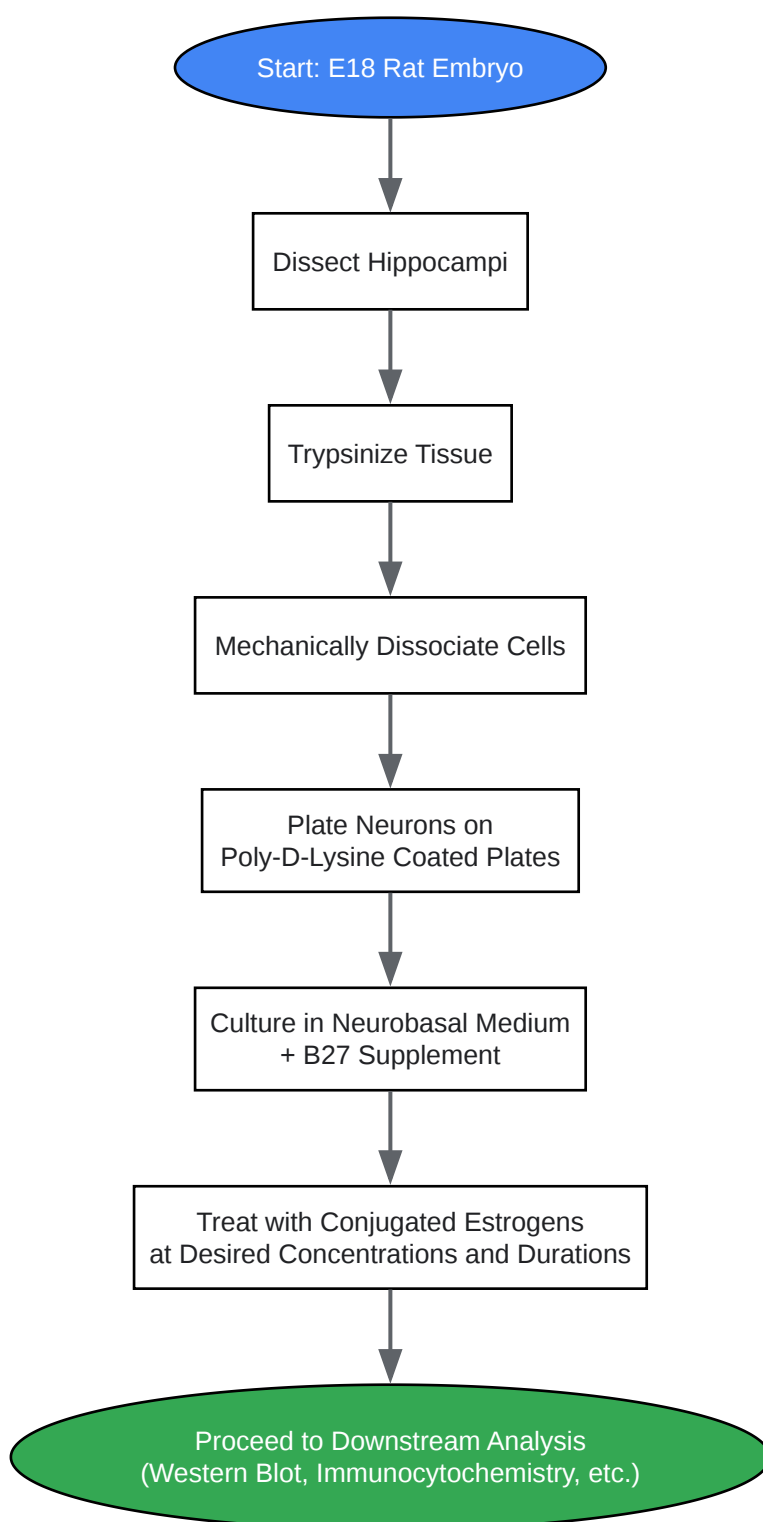

[Click to download full resolution via product page](#)

Caption: Primary Neuronal Culture Workflow.

Materials:

- E18 timed-pregnant Sprague-Dawley rat
- Hanks' Balanced Salt Solution (HBSS), Ca²⁺/Mg²⁺-free
- 0.25% Trypsin-EDTA
- Fetal Bovine Serum (FBS)
- Neurobasal medium supplemented with B-27, GlutaMAX, and Penicillin-Streptomycin
- Poly-D-lysine coated culture plates/coverslips
- **Conjugated estrogen sodium** stock solutions (in DMSO)

Procedure:

- Euthanize the pregnant rat according to institutional guidelines and harvest the E18 embryos.
- Dissect the hippocampi from the embryonic brains in ice-cold HBSS.
- Mince the tissue and incubate in 0.25% Trypsin-EDTA at 37°C for 15 minutes.
- Neutralize the trypsin with an equal volume of media containing 10% FBS.
- Gently triturate the tissue with a fire-polished Pasteur pipette to obtain a single-cell suspension.
- Centrifuge the cell suspension and resuspend the pellet in Neurobasal medium.
- Plate the neurons at a desired density onto Poly-D-lysine coated plates or coverslips.

- Culture the neurons at 37°C in a 5% CO₂ incubator, changing half the medium every 3-4 days.
- After a desired number of days in vitro (DIV), treat the neurons with various concentrations of conjugated estrogens for the specified time points.
- Following treatment, cells are ready for downstream applications.

Western Blot Analysis of ERK and Akt Phosphorylation

This protocol details the detection of phosphorylated (activated) ERK and Akt in neuronal lysates following estrogen treatment.

Materials:

- Primary neuronal cultures treated with conjugated estrogens
- RIPA lysis buffer with protease and phosphatase inhibitors
- BCA Protein Assay Kit
- SDS-PAGE gels and running buffer
- PVDF membrane
- Blocking buffer (5% BSA or non-fat dry milk in TBST)
- Primary antibodies: anti-phospho-ERK1/2, anti-total-ERK1/2, anti-phospho-Akt, anti-total-Akt, anti- β -actin
- HRP-conjugated secondary antibody
- Chemiluminescent substrate

Procedure:

- Lyse the treated neuronal cells on ice with RIPA buffer.
- Determine the protein concentration of the lysates using a BCA assay.

- Denature equal amounts of protein by boiling in Laemmli sample buffer.
- Separate the proteins by SDS-PAGE and transfer them to a PVDF membrane.
- Block the membrane with blocking buffer for 1 hour at room temperature.
- Incubate the membrane with primary antibodies against the phosphorylated and total forms of ERK and Akt overnight at 4°C. A loading control like β -actin should also be probed.
- Wash the membrane and incubate with the appropriate HRP-conjugated secondary antibody for 1 hour at room temperature.
- Detect the protein bands using a chemiluminescent substrate and an imaging system.
- Quantify the band intensities and normalize the phosphorylated protein levels to the total protein levels.

Co-Immunoprecipitation of ER α and Signaling Partners

This protocol is used to determine if ER α physically interacts with other signaling proteins (e.g., Src, p85 subunit of PI3K) upon estrogen stimulation.

Materials:

- Neuronal cell lysates
- Anti-ER α antibody for immunoprecipitation
- Protein A/G agarose or magnetic beads
- Wash buffer (e.g., modified RIPA buffer)
- Elution buffer
- Primary antibodies for Western blotting (e.g., anti-Src, anti-p85)

Procedure:

- Pre-clear the neuronal cell lysates with Protein A/G beads to reduce non-specific binding.

- Incubate the pre-cleared lysate with an anti-ER α antibody overnight at 4°C with gentle rotation.
- Add Protein A/G beads to the lysate-antibody mixture and incubate for 2-4 hours at 4°C to capture the antibody-protein complexes.
- Wash the beads several times with wash buffer to remove non-specifically bound proteins.
- Elute the immunoprecipitated proteins from the beads using elution buffer or by boiling in sample buffer.
- Analyze the eluted proteins by Western blotting using antibodies against the suspected interacting proteins.

Luciferase Reporter Gene Assay for ER α Activity

This assay measures the transcriptional activity of ER α in response to conjugated estrogens.

Materials:

- Neuronal cell line (e.g., SH-SY5Y)
- Luciferase reporter plasmid containing an Estrogen Response Element (ERE) upstream of the luciferase gene
- Transfection reagent
- Conjugated estrogen solutions
- Luciferase assay reagent

Procedure:

- Co-transfect the neuronal cells with the ERE-luciferase reporter plasmid and a control plasmid (e.g., expressing Renilla luciferase for normalization).
- After 24 hours, treat the transfected cells with various concentrations of conjugated estrogens.

- After an appropriate incubation period (e.g., 24 hours), lyse the cells.
- Measure the firefly and Renilla luciferase activities using a luminometer and the appropriate assay reagents.
- Normalize the firefly luciferase activity to the Renilla luciferase activity to control for transfection efficiency.
- Calculate the fold induction of luciferase activity relative to the vehicle-treated control.

Conclusion

Conjugated estrogen sodium exerts a complex and multifaceted influence on neuronal cells through a combination of rapid, non-genomic signaling and slower, genomic pathways. The activation of pro-survival cascades like the MAPK/ERK and PI3K/Akt pathways underscores the neuroprotective potential of these compounds. This technical guide provides a foundational understanding of these signaling networks, supported by available quantitative data and detailed experimental protocols. Further research is warranted to fully elucidate the specific contributions of each component of **conjugated estrogen sodium** to neuronal function and to translate these findings into effective therapeutic interventions for neurological disorders.

Need Custom Synthesis?

BenchChem offers custom synthesis for rare earth carbides and specific isotopic labeling.

Email: info@benchchem.com or [Request Quote Online](#).

References

- 1. Differential Ligand Binding Affinities of Human Estrogen Receptor- α Isoforms - PMC [[pmc.ncbi.nlm.nih.gov](https://pubmed.ncbi.nlm.nih.gov/)]
- 2. Estrogen Signaling in ER α -Negative Breast Cancer: ER β and GPER - PMC [[pmc.ncbi.nlm.nih.gov](https://pubmed.ncbi.nlm.nih.gov/)]
- 3. Frontiers | The Impact of Estrogen and Estrogen-Like Molecules in Neurogenesis and Neurodegeneration: Beneficial or Harmful? [[frontiersin.org](https://www.frontiersin.org/)]
- 4. Estrogen-Induced Activation of Mitogen-Activated Protein Kinase in Cerebral Cortical Explants: Convergence of Estrogen and Neurotrophin Signaling Pathways - PMC

[pmc.ncbi.nlm.nih.gov]

- 5. PI3 Kinase/Akt Activation Mediates Estrogen and IGF-1 Nigral DA Neuronal Neuroprotection Against a Unilateral Rat Model of Parkinson's Disease - PMC [pmc.ncbi.nlm.nih.gov]
- 6. Frontiers | Estradiol Activates PI3K/Akt/GSK3 Pathway Under Chronic Neurodegenerative Conditions Triggered by Perinatal Asphyxia [frontiersin.org]
- 7. researchgate.net [researchgate.net]
- To cite this document: BenchChem. [A Technical Guide to Conjugated Estrogen Sodium Signaling Pathways in Neuronal Cells]. BenchChem, [2025]. [Online PDF]. Available at: [https://www.benchchem.com/product/b15541981#conjugated-estrogen-sodium-signaling-pathways-in-neuronal-cells]

Disclaimer & Data Validity:

The information provided in this document is for Research Use Only (RUO) and is strictly not intended for diagnostic or therapeutic procedures. While BenchChem strives to provide accurate protocols, we make no warranties, express or implied, regarding the fitness of this product for every specific experimental setup.

Technical Support: The protocols provided are for reference purposes. Unsure if this reagent suits your experiment? [[Contact our Ph.D. Support Team for a compatibility check](#)]

Need Industrial/Bulk Grade? [Request Custom Synthesis Quote](#)

BenchChem

Our mission is to be the trusted global source of essential and advanced chemicals, empowering scientists and researchers to drive progress in science and industry.

Contact

Address: 3281 E Guasti Rd
Ontario, CA 91761, United States
Phone: (601) 213-4426
Email: info@benchchem.com