

A Technical Guide to Bioorthogonal Labeling with AF488 Azide

Author: BenchChem Technical Support Team. **Date:** December 2025

Compound of Interest

Compound Name: AF488 azide

Cat. No.: B12376829

[Get Quote](#)

For Researchers, Scientists, and Drug Development Professionals

This in-depth technical guide provides a comprehensive overview of bioorthogonal labeling using **AF488 azide**, a powerful tool for fluorescently tagging biomolecules in complex biological systems. We will delve into the core principles of this technology, the properties of the AF488 fluorophore, detailed experimental protocols, and its applications in modern research and drug development.

Introduction to Bioorthogonal Chemistry

Bioorthogonal chemistry refers to chemical reactions that can occur inside living systems without interfering with native biochemical processes.^[1] This concept, introduced by Carolyn Bertozzi, has revolutionized our ability to study biomolecules in their natural environment.^[1] The strategy typically involves a two-step process:

- **Metabolic or Genetic Incorporation:** A biomolecule of interest is tagged with a "chemical handle," a functional group not naturally found in the biological system, such as an azide.^[2]
- **Bioorthogonal Ligation:** The chemical handle is then selectively reacted with a complementary probe, in this case, a fluorescent dye like **AF488 azide**, enabling visualization and tracking.^[2]

The azide group is an ideal chemical reporter due to its small size, which minimizes perturbations to the biomolecule's structure and function, and its near-complete absence in

biological systems, ensuring high specificity of the labeling reaction.[1]

AF488 Azide: A Bright and Photostable Fluorescent Probe

AF488 azide is a derivative of the Alexa Fluor 488 dye, one of the most widely used fluorophores in life sciences. It is a bright, green-fluorescent dye known for its high photostability and pH resistance, making it an excellent choice for a variety of imaging applications, including confocal microscopy and flow cytometry. The azide functional group allows for its covalent attachment to alkyne-modified biomolecules through "click chemistry."

Physicochemical Properties of AF488 Azide

The performance of a fluorophore is determined by its key photophysical parameters. The following table summarizes the quantitative data for **AF488 azide** and its variants.

Property	Value	Reference(s)
Excitation Maximum (λ_{ex})	~494 - 499 nm	
Emission Maximum (λ_{em})	~517 - 520 nm	
Molar Extinction Coefficient (ϵ)	~71,000 - 73,000 $\text{cm}^{-1}\text{M}^{-1}$	
Fluorescence Quantum Yield (Φ)	~0.91 - 0.92	
Solubility	Water, DMSO, DMF	

Bioorthogonal Labeling Chemistries with AF488 Azide

Two primary bioorthogonal reactions are employed to conjugate **AF488 azide** to alkyne-containing biomolecules: the Copper(I)-Catalyzed Azide-Alkyne Cycloaddition (CuAAC) and the Strain-Promoted Azide-Alkyne Cycloaddition (SPAAC).

Copper(I)-Catalyzed Azide-Alkyne Cycloaddition (CuAAC)

The CuAAC reaction is a highly efficient and specific click reaction that forms a stable triazole linkage between a terminal alkyne and an azide. This reaction is catalyzed by copper(I), which is typically generated in situ from a copper(II) salt (e.g., CuSO_4) using a reducing agent like sodium ascorbate.

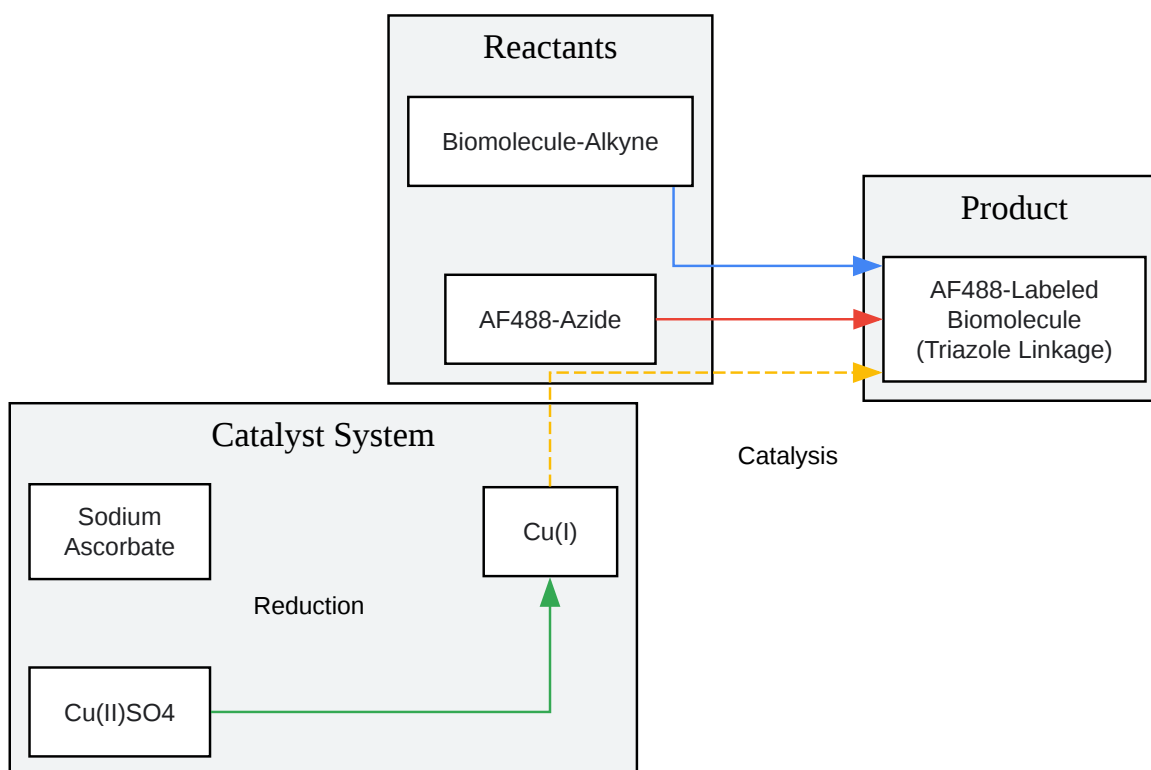

[Click to download full resolution via product page](#)

Caption: Catalytic cycle of the CuAAC reaction for labeling with **AF488 azide**.

While highly efficient, the cytotoxicity of the copper catalyst can be a concern for live-cell imaging. However, the use of copper-chelating ligands can mitigate this toxicity and, in some cases, even accelerate the reaction.

Strain-Promoted Azide-Alkyne Cycloaddition (SPAAC)

To circumvent the issue of copper toxicity, SPAAC was developed. This reaction utilizes a strained cyclooctyne, such as dibenzocyclooctyne (DBCO), which reacts spontaneously with an azide without the need for a catalyst. This makes SPAAC ideal for labeling in living cells and organisms.

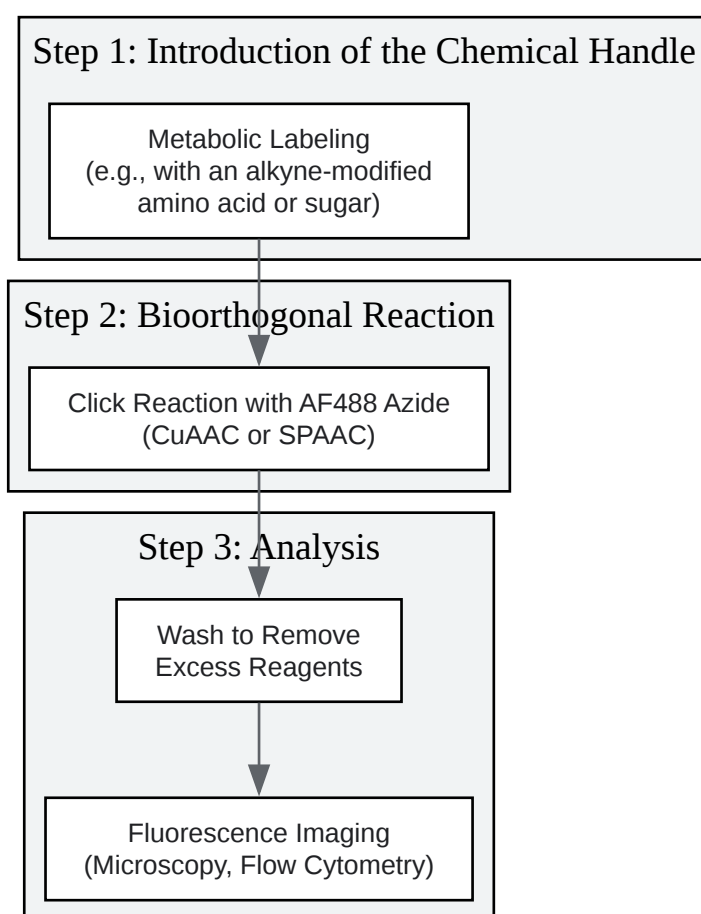
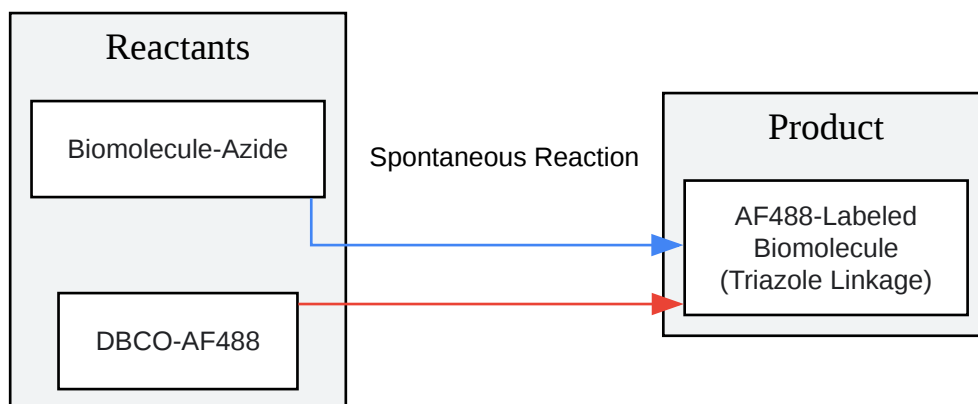

[Click to download full resolution via product page](#)

Need Custom Synthesis?

BenchChem offers custom synthesis for rare earth carbides and specific isotopic labeling.

Email: info@benchchem.com or [Request Quote Online](#).

References

- 1. Azide-based bioorthogonal chemistry: Reactions and its advances in cellular and biomolecular imaging - PMC [pmc.ncbi.nlm.nih.gov]
- 2. pubs.acs.org [pubs.acs.org]
- To cite this document: BenchChem. [A Technical Guide to Bioorthogonal Labeling with AF488 Azide]. BenchChem, [2025]. [Online PDF]. Available at: [https://www.benchchem.com/product/b12376829#introduction-to-bioorthogonal-labeling-with-af488-azide]

Disclaimer & Data Validity:

The information provided in this document is for Research Use Only (RUO) and is strictly not intended for diagnostic or therapeutic procedures. While BenchChem strives to provide accurate protocols, we make no warranties, express or implied, regarding the fitness of this product for every specific experimental setup.

Technical Support: The protocols provided are for reference purposes. Unsure if this reagent suits your experiment? [[Contact our Ph.D. Support Team for a compatibility check](#)]

Need Industrial/Bulk Grade? [Request Custom Synthesis Quote](#)

BenchChem

Our mission is to be the trusted global source of essential and advanced chemicals, empowering scientists and researchers to drive progress in science and industry.

Contact

Address: 3281 E Guasti Rd

Ontario, CA 91761, United States

Phone: (601) 213-4426

Email: info@benchchem.com

