

A Quantum Chemical Perspective on the Phosphorus-Nitrogen Bond: A Technical Guide

Author: BenchChem Technical Support Team. **Date:** December 2025

Compound of Interest

Compound Name: *Phosphorous nitride*

Cat. No.: *B101387*

[Get Quote](#)

For Researchers, Scientists, and Drug Development Professionals

Introduction

The phosphorus-nitrogen (PN) bond is a fundamental interaction in chemistry, underpinning the structure and reactivity of a diverse array of molecules, from inorganic polymers and flame retardants to biologically active compounds and ligands in catalysis. The nuanced nature of this bond, which can range from a classic single bond to a triple bond, dictates the geometry, stability, and electronic properties of these molecules. Understanding the intricacies of PN bonding is therefore crucial for the rational design of new materials and therapeutic agents.

This technical guide provides an in-depth exploration of the PN bond through the lens of modern quantum chemical methods. It is designed to furnish researchers, scientists, and drug development professionals with a comprehensive overview of the theoretical tools available to dissect and understand this critical chemical linkage. By presenting quantitative data, detailed methodologies, and clear visualizations, this guide aims to bridge the gap between computational theory and practical application in the laboratory.

Theoretical Methods for Interrogating the PN Bond

The characterization of the PN bond relies on a suite of sophisticated quantum chemical techniques that provide insights into its electronic structure and energetic properties. The primary methods employed are geometry optimization and vibrational frequency calculations, which yield fundamental information about the molecular structure and the strength of the

bond. To gain a deeper understanding of the nature of the interaction, several analytical methods are commonly applied to the calculated wave function.

Natural Bond Orbital (NBO) Analysis: This method translates the complex, delocalized molecular orbitals obtained from a quantum chemical calculation into a more intuitive picture of localized bonds, lone pairs, and antibonding orbitals, closely resembling the familiar Lewis structures. NBO analysis provides quantitative information about the hybridization of the atomic orbitals involved in the PN bond, the bond polarity, and the extent of electron delocalization through donor-acceptor interactions.

Quantum Theory of Atoms in Molecules (QTAIM): QTAIM is a powerful method that analyzes the topology of the electron density to partition a molecule into atomic basins. By examining the properties of the electron density at the bond critical point (BCP) between the phosphorus and nitrogen atoms, one can characterize the nature of the interaction. Key descriptors include the electron density (ρ), its Laplacian ($\nabla^2\rho$), and the total energy density ($H(r)$), which help to distinguish between shared (covalent) and closed-shell (ionic or van der Waals) interactions.

Energy Decomposition Analysis (EDA): EDA is a valuable tool for dissecting the total interaction energy between two fragments—in this case, a phosphorus-containing fragment and a nitrogen-containing fragment—into physically meaningful components. A typical EDA scheme partitions the interaction energy into electrostatic, Pauli repulsion, and orbital interaction terms. The orbital interaction term, which represents the covalent contribution to the bond, can be further decomposed into contributions from σ and π orbitals, providing a detailed picture of the bonding mechanism.

Data Presentation: A Comparative Analysis of PN Bonds

To illustrate the utility of these quantum chemical methods, the following tables summarize key computed properties for simple molecules representing PN single, double, and triple bonds. These molecules, aminophosphine ($\text{H}_2\text{P-NH}_2$), phosphinidene-amine (HP=NH), and phosphorus mononitride (P=N), serve as archetypal examples of the different bonding motifs. The data has been compiled from various high-level theoretical studies to provide a comparative overview.

Molecular Property	H ₂ P-NH ₂ (Single Bond)	HP=NH (Double Bond)	P≡N (Triple Bond)	Computational Method
PN Bond Length (Å)	~1.70	~1.56	1.491	Various (e.g., MP2, CCSD(T))
PN Vibrational Frequency (cm ⁻¹)	~900	~1100	1337	Various (e.g., DFT, MP2)
PN Bond Dissociation Energy (kcal/mol)	~80	~120	~117	G3X, B3LYP

Table 1: Comparison of Key Molecular Properties for PN Single, Double, and Triple Bonds. This table highlights the expected trends of decreasing bond length and increasing vibrational frequency with increasing bond order. The bond dissociation energies also generally increase with bond order, reflecting the greater strength of multiple bonds.

NBO Parameter	H ₂ P-NH ₂ (Single Bond)	HP=NH (Double Bond)	P≡N (Triple Bond)	Computational Method
Wiberg Bond Index	~0.9	~1.8	~2.7	B3LYP/6-311+G(d,p)
Natural Charge on P	+0.4 to +0.6	+0.2 to +0.4	-0.2 to 0.0	B3LYP/6-311+G(d,p)
Natural Charge on N	-0.8 to -1.0	-0.6 to -0.8	+0.2 to 0.0	B3LYP/6-311+G(d,p)

Table 2: Natural Bond Orbital (NBO) Analysis of PN Bonds. The Wiberg Bond Index, a measure of bond order, clearly reflects the single, double, and triple bond character of the selected molecules. The natural charges reveal a significant polarity in the single and double bonds, with phosphorus being electropositive and nitrogen electronegative. In the triple bond of P≡N, the charge distribution is much less polarized.

QTAIM Parameter at BCP	H ₂ P-NH ₂ (Single Bond)	HP=NH (Double Bond)	P≡N (Triple Bond)	Computational Method
Electron Density, $\rho(r)$	~0.20	~0.35	~0.45	B3LYP/6-311+G(d,p)
Laplacian of $\rho(r)$, $\nabla^2\rho(r)$	Negative	Negative	Negative	B3LYP/6-311+G(d,p)
Total Energy Density, H(r)	Negative	Negative	Negative	B3LYP/6-311+G(d,p)

Table 3: Quantum Theory of Atoms in Molecules (QTAIM) Analysis of PN Bonds. The increasing electron density at the bond critical point (BCP) from single to triple bond is indicative of increasing bond strength and covalency. The negative values of the Laplacian and total energy density for all three bond types are characteristic of shared-shell (covalent) interactions.

EDA Component (kcal/mol)	H ₂ P-NH ₂ (Single Bond)	HP=NH (Double Bond)	P≡N (Triple Bond)	Computational Method
Electrostatic Interaction	Attractive	Attractive	Attractive	BP86/TZ2P
Pauli Repulsion	Repulsive	Repulsive	Repulsive	BP86/TZ2P
Orbital Interaction	Dominantly Attractive (σ)	Strongly Attractive ($\sigma + \pi$)	Very Strongly Attractive ($\sigma + 2\pi$)	BP86/TZ2P

Table 4: Energy Decomposition Analysis (EDA) of PN Bonds. This table qualitatively illustrates how the nature of the orbital interaction changes with bond order. While the electrostatic interaction is always attractive and the Pauli repulsion is always repulsive, the orbital interaction term becomes increasingly dominant and involves contributions from π orbitals as the bond order increases from single to triple.

Methodologies

A typical quantum chemical study of PN bonding involves a series of well-defined computational steps. The following provides a generalized protocol for such an investigation.

1. **Molecular Structure Generation:** The initial step involves building the three-dimensional structure of the PN-containing molecule of interest. This can be done using molecular modeling software.
2. **Geometry Optimization:** The initial structure is then optimized to find the minimum energy geometry. This is typically performed using Density Functional Theory (DFT) with a functional such as B3LYP, and a sufficiently large basis set, for example, 6-311+G(d,p). The optimization process is complete when the forces on all atoms are close to zero and the energy has converged.
3. **Vibrational Frequency Calculation:** Once the geometry is optimized, a vibrational frequency calculation is performed at the same level of theory. This serves two purposes: first, to confirm that the optimized structure is a true minimum on the potential energy surface (indicated by the absence of imaginary frequencies), and second, to obtain the vibrational frequencies, including the PN stretching frequency, which is a key indicator of bond strength.
4. **Wavefunction Analysis:** With the optimized geometry and converged wavefunction, the detailed bonding analysis can be performed.
 - **NBO Analysis:** This is typically requested as a post-processing step in the quantum chemistry software. The output will provide information on natural charges, bond orders (e.g., Wiberg Bond Index), and the composition of the natural bond orbitals.
 - **QTAIM Analysis:** This requires specialized software that can read the wavefunction file from the quantum chemistry calculation. The analysis will locate the bond critical points and calculate the topological properties of the electron density at these points.
 - **EDA:** This analysis is performed by defining the molecule as two interacting fragments (one containing the P atom and the other the N atom). The calculation then partitions the interaction energy between these fragments into the various components.

Visualizations

To further elucidate the concepts discussed, the following diagrams, generated using the DOT language, illustrate key workflows and relationships in the quantum chemical study of PN bonding.

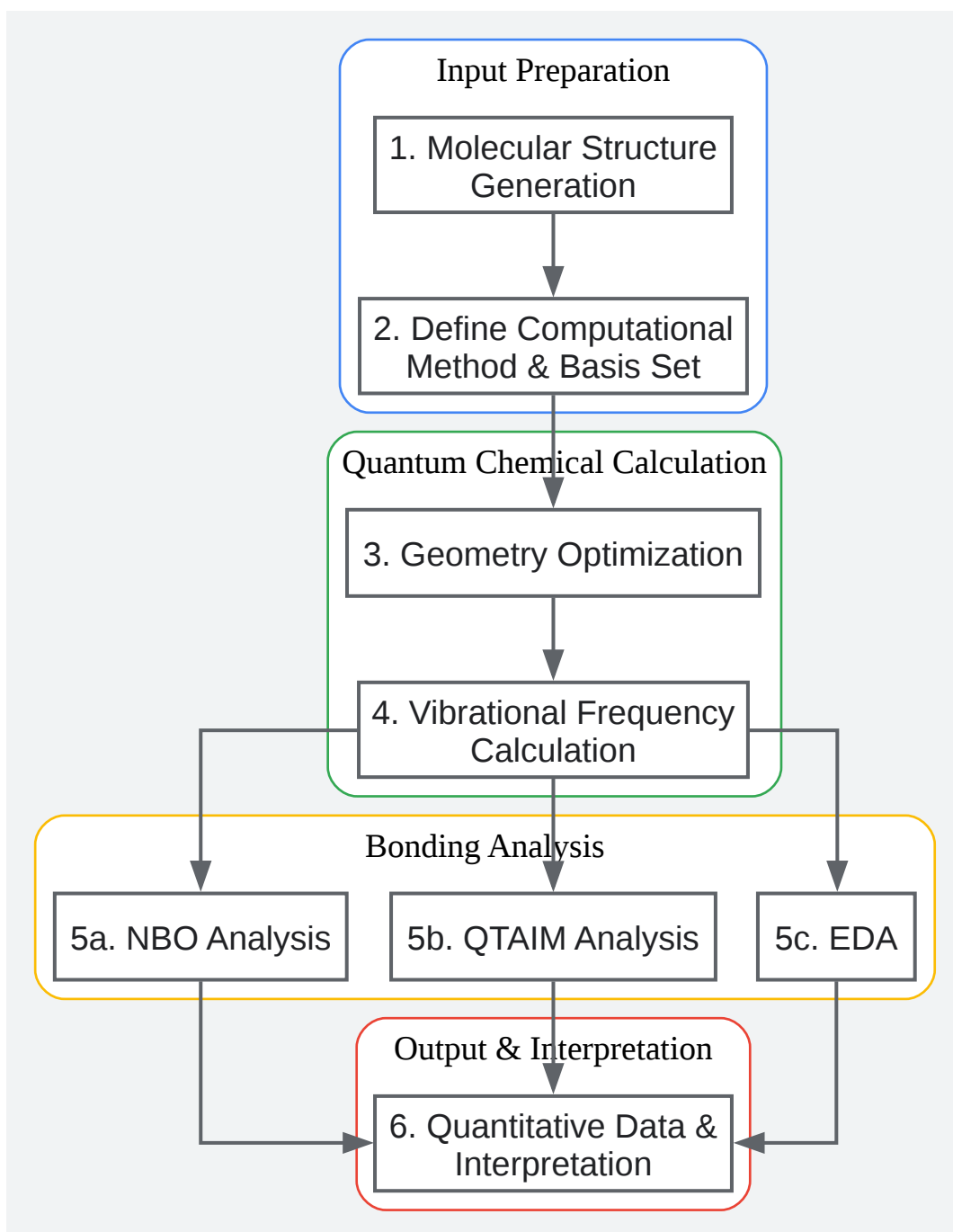

[Click to download full resolution via product page](#)

A typical workflow for the quantum chemical study of PN bonding.

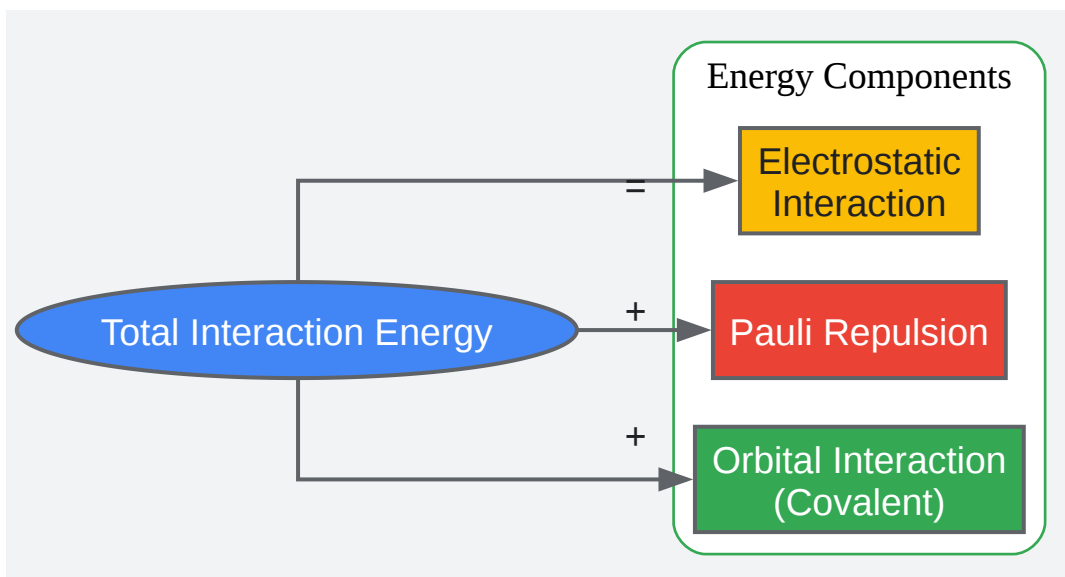

[Click to download full resolution via product page](#)

Components of Energy Decomposition Analysis (EDA).

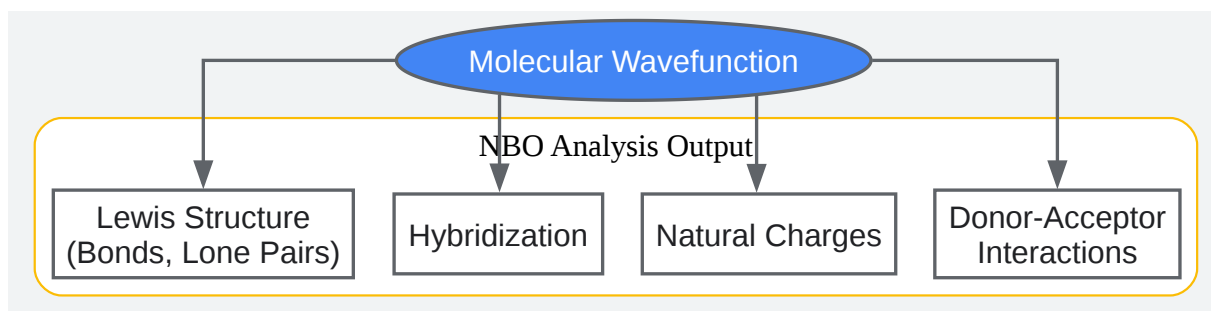

[Click to download full resolution via product page](#)

Key outputs of a Natural Bond Orbital (NBO) analysis.

Conclusion

The quantum chemical study of PN bonding offers a powerful and insightful approach to understanding the fundamental nature of this important chemical linkage. Through the application of methods such as NBO, QTAIM, and EDA, researchers can move beyond simple structural representations to a quantitative and nuanced understanding of the electronic interactions that govern molecular properties. The data and methodologies presented in this guide provide a framework for the investigation of PN-containing systems, with the ultimate

goal of facilitating the design and development of novel molecules with tailored functionalities for a wide range of applications in materials science and drug discovery. The continued development of computational methods promises even greater accuracy and predictive power, further solidifying the role of theoretical chemistry as an indispensable tool in modern chemical research.

- To cite this document: BenchChem. [A Quantum Chemical Perspective on the Phosphorus-Nitrogen Bond: A Technical Guide]. BenchChem, [2025]. [Online PDF]. Available at: [<https://www.benchchem.com/product/b101387#quantum-chemical-study-of-pn-bonding>]

Disclaimer & Data Validity:

The information provided in this document is for Research Use Only (RUO) and is strictly not intended for diagnostic or therapeutic procedures. While BenchChem strives to provide accurate protocols, we make no warranties, express or implied, regarding the fitness of this product for every specific experimental setup.

Technical Support: The protocols provided are for reference purposes. Unsure if this reagent suits your experiment? [[Contact our Ph.D. Support Team for a compatibility check](#)]

Need Industrial/Bulk Grade? [Request Custom Synthesis Quote](#)

BenchChem

Our mission is to be the trusted global source of essential and advanced chemicals, empowering scientists and researchers to drive progress in science and industry.

Contact

Address: 3281 E Guasti Rd

Ontario, CA 91761, United States

Phone: (601) 213-4426

Email: info@benchchem.com