

A Comparative Pharmacokinetic Profile of Substituted Quinoline Derivatives: A Guide for Researchers

Author: BenchChem Technical Support Team. **Date:** December 2025

Compound of Interest

Compound Name: N-(4-AMINO-2-METHYLQUINOLIN-6-YL)ACETAMIDE

Cat. No.: B1277882

[Get Quote](#)

For researchers, scientists, and drug development professionals, this guide provides a comparative overview of the pharmacokinetic profiles of various substituted quinoline derivatives. The information is compiled from preclinical studies and is intended to facilitate the selection and development of quinoline-based therapeutic agents.

The quinoline scaffold is a prominent structural motif in a wide array of therapeutic agents, demonstrating efficacy in treating malaria, cancer, and microbial infections.[1][2][3] The pharmacokinetic properties of these derivatives, which govern their absorption, distribution, metabolism, and excretion (ADME), are critically influenced by the nature and position of their substituents. Understanding these structure-pharmacokinetic relationships is paramount for optimizing drug design and enhancing therapeutic outcomes.

Comparative Pharmacokinetic Parameters

The following tables summarize key in vivo pharmacokinetic parameters and in vitro metabolism data for a selection of substituted quinoline derivatives, compiled from various preclinical studies. It is important to note that direct comparison of these values should be approached with caution, as experimental conditions such as animal models, dosage, and analytical methodologies can vary between studies.

In Vivo Pharmacokinetic Data

This table presents experimentally determined pharmacokinetic parameters of several substituted quinoline derivatives in animal models.

Compound/ Derivative	Animal Model	Dose & Route	Cmax	Tmax (h)	t1/2 (h)	AUC	Oral Bioavailability (%)	Reference
WR 184806 (Antimalarial)	Mice	Oral	Peak plasma levels at 2-4 and 7-10 h	2-4 & 7-10	-	-	At least 77-85% absorption	[4]
2-n-propylquinoline (Antimalarial)	Mice	50 mg/kg, Oral	-	-	-	-	Effective in reducing parasite load	[5]
2-trans-epoxypropylquinoline (Antimalarial)	Mice	50 mg/kg, Oral	-	-	-	-	Effective in reducing parasite load	[5]
(E)-3-quinolin-2-ylacrylonitrile (Antimalarial)	Mice	12.5 mg/kg/day for 10 days, Oral	-	-	-	-	Reduced parasite burden by 60-70%	[5]
Quinoline 3-Carbox	Mouse	-	High exposure of	-	-	-	Low clearance	[6]

amide	parent	predicted
Derivatives	compounds	from
		in vitro
		data

C_{max}: Maximum plasma concentration; T_{max}: Time to reach C_{max}; t_{1/2}: Half-life; AUC: Area under the plasma concentration-time curve. Dashes indicate data not reported in the cited source.

In Vitro Metabolism Data

This table summarizes the in vitro metabolic stability of a series of quinoline 3-carboxamide derivatives in liver microsomes from different species.

Compound Substituent	Species	In Vitro Clearance	Metabolizing Enzymes
Various substituents on quinoline moiety	Mouse, Rat, Dog, Human	Low	Cytochrome P450
Methyl vs. Ethyl at carboxamide	Mouse, Rat, Dog, Human	Enhanced with ethyl group	Cytochrome P450

Experimental Protocols

Detailed methodologies are crucial for the reproducibility and validation of pharmacokinetic data. Below are representative protocols for key in vitro assays used to characterize the ADME properties of substituted quinoline derivatives.

Caco-2 Permeability Assay

This assay is widely used to predict the intestinal absorption of drug candidates.

Objective: To determine the rate of transport of a compound across a monolayer of human colon adenocarcinoma cells (Caco-2), which serves as an in vitro model of the intestinal epithelium.

Methodology:

- **Cell Culture:** Caco-2 cells are seeded on semipermeable filter supports in multi-well plates and cultured for approximately 21 days to allow for differentiation and the formation of a confluent monolayer with tight junctions.
- **Monolayer Integrity Check:** The integrity of the cell monolayer is verified by measuring the transepithelial electrical resistance (TEER) and/or by assessing the permeability of a fluorescent marker with low permeability (e.g., Lucifer Yellow).
- **Transport Experiment:**
 - The test compound (typically at a concentration of 10 μ M) is added to the apical (donor) side of the monolayer to assess absorption (A-to-B transport).
 - To evaluate efflux, the compound is added to the basolateral (receiver) side (B-to-A transport).
 - Samples are collected from the receiver compartment at predetermined time points (e.g., 30, 60, 90, 120 minutes).
- **Sample Analysis:** The concentration of the test compound in the collected samples is quantified using a sensitive analytical method, such as liquid chromatography-tandem mass spectrometry (LC-MS/MS).
- **Data Analysis:** The apparent permeability coefficient (P_{app}) is calculated using the following equation: $P_{app} = (dQ/dt) / (A * C_0)$
 - Where dQ/dt is the rate of appearance of the compound in the receiver compartment, A is the surface area of the filter, and C_0 is the initial concentration in the donor compartment.
 - The efflux ratio ($P_{app}(B-A) / P_{app}(A-B)$) is calculated to determine if the compound is a substrate for efflux transporters.

Liver Microsomal Stability Assay

This assay is used to evaluate the metabolic stability of a compound by liver enzymes, primarily cytochrome P450s.

Objective: To determine the rate of metabolism of a test compound when incubated with liver microsomes.

Methodology:

- **Incubation Mixture Preparation:** A reaction mixture is prepared containing liver microsomes (from human or other species), a buffered solution (e.g., phosphate buffer, pH 7.4), and the test compound.
- **Reaction Initiation:** The metabolic reaction is initiated by adding a cofactor solution, typically containing NADPH. Control incubations without the cofactor are also performed.
- **Incubation:** The reaction mixtures are incubated at 37°C, and aliquots are collected at various time points (e.g., 0, 5, 15, 30, 60 minutes).
- **Reaction Termination:** The reaction in the collected aliquots is stopped by adding a cold organic solvent (e.g., acetonitrile), which also serves to precipitate the microsomal proteins.
- **Sample Analysis:** After centrifugation to remove the precipitated proteins, the supernatant is analyzed by LC-MS/MS to quantify the remaining concentration of the parent compound.
- **Data Analysis:** The natural logarithm of the percentage of the remaining parent compound is plotted against time. The slope of the linear portion of this plot is used to calculate the in vitro half-life ($t_{1/2}$) and the intrinsic clearance (CL_{int}).

Signaling Pathways and Experimental Workflows

Many substituted quinoline derivatives exert their therapeutic effects, particularly in cancer, by targeting specific signaling pathways. The following diagrams, generated using the DOT language, illustrate key signaling cascades often implicated in the mechanism of action of these compounds.

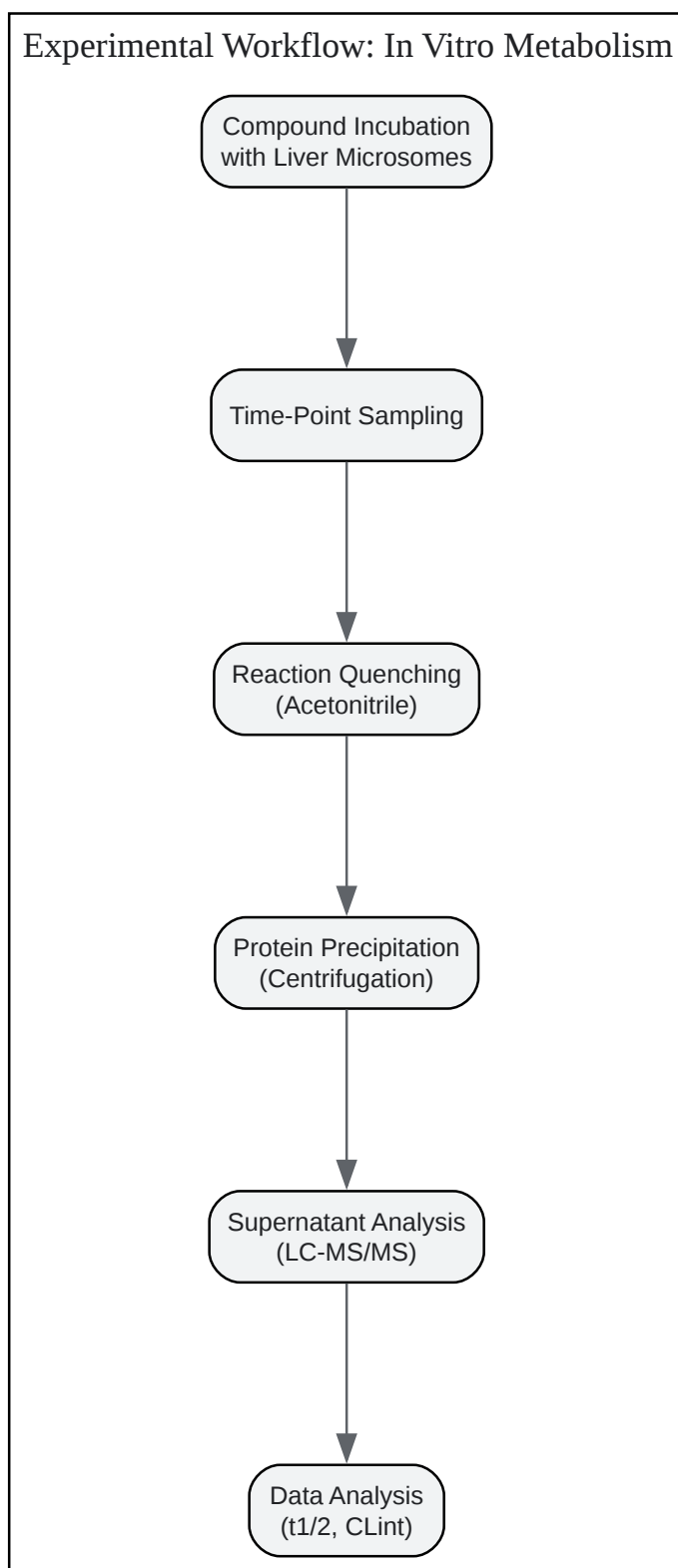

[Click to download full resolution via product page](#)

Caption: Workflow for assessing in vitro metabolic stability.

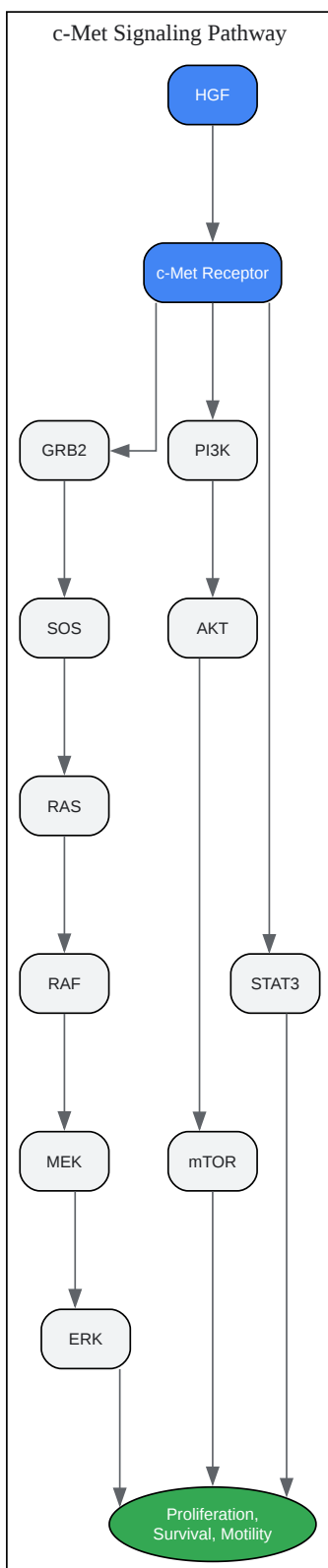

[Click to download full resolution via product page](#)

Caption: The HGF/c-Met signaling cascade.

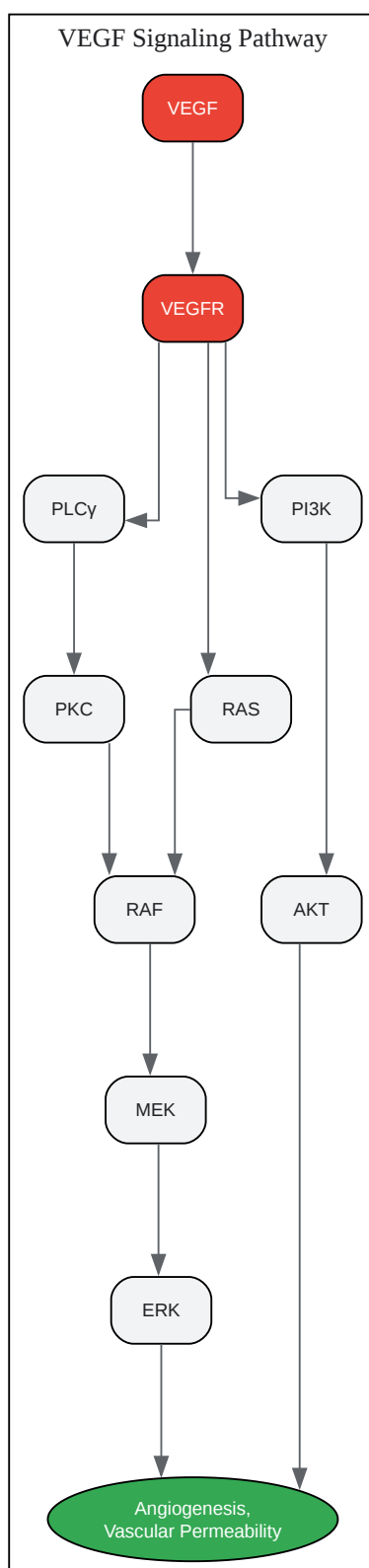

[Click to download full resolution via product page](#)

Caption: The VEGF signaling pathway in angiogenesis.

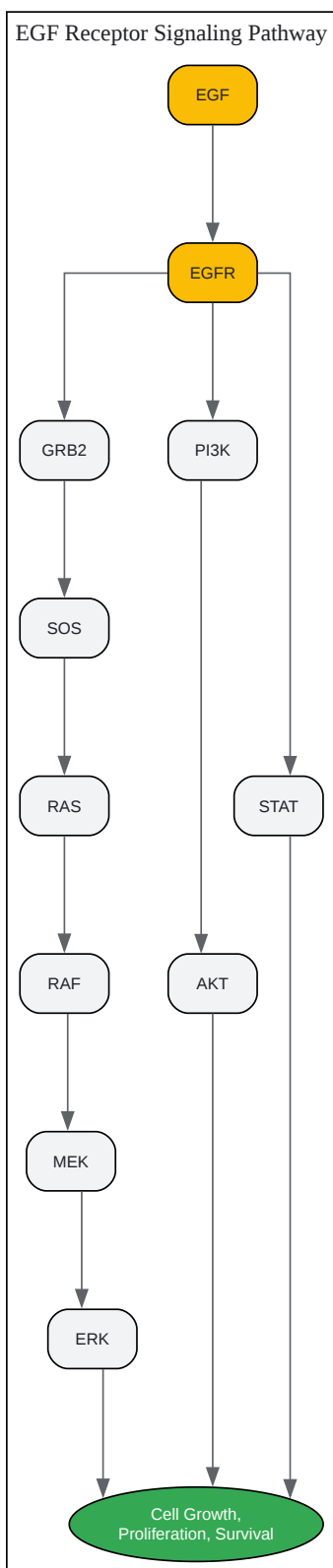

[Click to download full resolution via product page](#)

Caption: The EGF receptor signaling cascade.

Need Custom Synthesis?

BenchChem offers custom synthesis for rare earth carbides and specific isotopic labeling.

Email: info@benchchem.com or [Request Quote Online](#).

References

- 1. researchgate.net [researchgate.net]
- 2. Quinoline derivatives' biological interest for anti-malarial and anti-cancer activities: an overview - PMC [pmc.ncbi.nlm.nih.gov]
- 3. neuroquantology.com [neuroquantology.com]
- 4. The absorption, distribution, and excretion in mice of a quinolinemethanol antimalarial, 2,8-bis(trifluoromethyl)-4-(1-hydroxy-3-(N-t-butylamino)propyl)quinoline phosphate (WR 184,806) - PubMed [pubmed.ncbi.nlm.nih.gov]
- 5. The Potential of 2-Substituted Quinolines as Antileishmanial Drug Candidates - PMC [pmc.ncbi.nlm.nih.gov]
- 6. In vitro metabolism and in vivo pharmacokinetics of quinoline 3-carboxamide derivatives in various species - PubMed [pubmed.ncbi.nlm.nih.gov]
- To cite this document: BenchChem. [A Comparative Pharmacokinetic Profile of Substituted Quinoline Derivatives: A Guide for Researchers]. BenchChem, [2025]. [Online PDF]. Available at: [<https://www.benchchem.com/product/b1277882#comparative-pharmacokinetic-profiling-of-substituted-quinoline-derivatives>]

Disclaimer & Data Validity:

The information provided in this document is for Research Use Only (RUO) and is strictly not intended for diagnostic or therapeutic procedures. While BenchChem strives to provide accurate protocols, we make no warranties, express or implied, regarding the fitness of this product for every specific experimental setup.

Technical Support: The protocols provided are for reference purposes. Unsure if this reagent suits your experiment? [[Contact our Ph.D. Support Team for a compatibility check](#)]

Need Industrial/Bulk Grade? [Request Custom Synthesis Quote](#)

BenchChem

Our mission is to be the trusted global source of essential and advanced chemicals, empowering scientists and researchers to drive progress in science and industry.

Contact

Address: 3281 E Guasti Rd

Ontario, CA 91761, United States

Phone: (601) 213-4426

Email: info@benchchem.com