

A Comparative Guide to the Substrate Specificity of GGPPS Isoforms

Author: BenchChem Technical Support Team. **Date:** December 2025

Compound of Interest

Compound Name: Geranylgeranyl pyrophosphate

Cat. No.: B1195527

[Get Quote](#)

For Researchers, Scientists, and Drug Development Professionals

Geranylgeranyl diphosphate synthase (GGPPS) is a key enzyme in the isoprenoid biosynthesis pathway, catalyzing the formation of the C20 molecule geranylgeranyl diphosphate (GGPP). GGPP serves as a crucial precursor for a vast array of essential molecules, including carotenoids, chlorophylls, gibberellins, and prenylated proteins.[1][2][3] Different isoforms of GGPPS exist across various organisms and even within different cellular compartments of the same organism, each potentially exhibiting unique substrate preferences and kinetic properties. [2][4][5] Understanding the substrate specificity of these isoforms is paramount for metabolic engineering, drug development, and fundamental biological research. This guide provides a comparative overview of the substrate specificity of different GGPPS isoforms, supported by experimental data and detailed methodologies.

Quantitative Comparison of Kinetic Parameters

The substrate specificity of an enzyme is quantitatively described by its kinetic parameters, primarily the Michaelis constant (K_m) and the catalytic rate constant (k_{cat}). K_m reflects the substrate concentration at which the reaction rate is half of the maximum velocity (V_{max}), indicating the affinity of the enzyme for its substrate. A lower K_m value signifies a higher affinity. The k_{cat} represents the turnover number, or the number of substrate molecules converted to product per enzyme molecule per unit of time. The ratio k_{cat}/K_m is a measure of the enzyme's catalytic efficiency.

The following table summarizes the kinetic parameters of various GGPPS isoforms with their allylic substrates (DMAPP, GPP, FPP) and isopentenyl pyrophosphate (IPP).

Isoform	Organism/Tissue	Substrate	Km (μM)	Vmax (nmol/min/mg)	kcat (s ⁻¹)	kcat/Km (M ⁻¹ s ⁻¹)	Reference(s)
Bovine Brain GGPPS	Bos taurus	DMAPP	33	-	-	-	[6]
GPP	0.80	-	-	-	[6]		
FPP	0.74	-	-	-	[6]		
IPP	2	-	-	-	[6]		
OsGGPP S1 (homodimer)	Oryza sativa	IPP	14.5 (with FPP)	-	-	-	[1]
OsGGPP S1/Os02g44780 (heterodimer)	Oryza sativa	IPP	1.0 (with FPP)	-	-	-	[1]
SIG1, SIG2, SIG3	Solanum lycopersicum	-	exhibit similar kinetic parameters	-	-	-	[7]
RcG/FPP S1	Rosa chinensis	IPP (with DMAPP for GPP production)	0.44	-	-	-	[8]
Heterodimeric GGPPS	Rosa chinensis	IPP (with DMAPP for GPP)	2.50 - 6.74	-	-	-	[8]

productio
n)

Note: The availability of complete kinetic data (K_m , k_{cat} , and V_{max}) for all isoforms is limited in the literature. The table reflects the reported values. A dash (-) indicates that the data was not provided in the cited source. The conditions under which these parameters were determined may vary between studies.

Experimental Protocols

The determination of GGPPS substrate specificity relies on robust enzymatic assays. Below are detailed methodologies for commonly employed techniques.

1. Radiochemical Assay for GGPPS Activity

This is a classic and highly sensitive method for measuring enzyme activity by tracking the incorporation of a radiolabeled substrate into the product.[\[9\]](#)

- Materials and Reagents:
 - Purified GGPPS isoform
 - Allylic substrates: Dimethylallyl pyrophosphate (DMAPP), Geranyl pyrophosphate (GPP), Farnesyl pyrophosphate (FPP)
 - Radiolabeled substrate: $[^{14}C]$ -Isopentenyl pyrophosphate ($[^{14}C]$ -IPP) or $[^3H]$ -IPP
 - Assay Buffer: 50 mM Tris-HCl (pH 7.5), 5 mM $MgCl_2$, 2 mM DTT
 - Stop Solution: Saturated NaCl or 6 M HCl
 - Extraction Solvent: Butanol or a mixture of chloroform and methanol
 - Scintillation cocktail and liquid scintillation counter
- Procedure:

- Prepare a reaction mixture containing the assay buffer, a specific concentration of the allylic substrate (e.g., FPP), and the purified GGPPS enzyme in a microcentrifuge tube.
- Pre-incubate the mixture at the optimal temperature for the enzyme (e.g., 37°C) for 5-10 minutes.
- Initiate the reaction by adding a known concentration of [14C]-IPP.
- Incubate the reaction for a defined period (e.g., 10-30 minutes), ensuring the reaction remains in the linear range.
- Terminate the reaction by adding the stop solution.
- Extract the radiolabeled product (e.g., [14C]-GGPP) using the extraction solvent. The unreacted [14C]-IPP will remain in the aqueous phase.
- Transfer the organic phase containing the product to a scintillation vial, evaporate the solvent, add the scintillation cocktail, and measure the radioactivity using a liquid scintillation counter.
- Calculate the amount of product formed based on the specific activity of the [14C]-IPP.
- To determine kinetic parameters, repeat the assay with varying concentrations of one substrate while keeping the other substrates at saturating concentrations.

2. Spectrophotometric Assay

This method provides a continuous, real-time measurement of enzyme activity by coupling the release of pyrophosphate (PPi), a product of the GGPPS reaction, to a detectable color change.[\[10\]](#)[\[11\]](#)

- Materials and Reagents:
 - Purified GGPPS isoform
 - Allylic substrates (DMAPP, GPP, FPP) and IPP
 - EnzChek™ Pyrophosphate Assay Kit (or similar) containing:

- 2-amino-6-mercapto-7-methylpurine ribonucleoside (MESG)
- Purine nucleoside phosphorylase (PNP)
- Inorganic pyrophosphatase
- Assay Buffer: 50 mM Tris-HCl (pH 7.5), 5 mM MgCl₂, 2 mM DTT
- Procedure:
 - Prepare a reaction mixture in a microplate well containing the assay buffer, MESG, PNP, inorganic pyrophosphatase, the GGPPS enzyme, and the allylic substrate.
 - Initiate the reaction by adding IPP.
 - The GGPPS reaction produces GGPP and PPI. The inorganic pyrophosphatase hydrolyzes PPI to two molecules of inorganic phosphate (Pi).
 - PNP catalyzes the phosphorolysis of MESG in the presence of Pi, releasing ribose 1-phosphate and 2-amino-6-mercapto-7-methylpurine.
 - This product causes a spectrophotometric shift in absorbance, which can be monitored in real-time at 360 nm.
 - The rate of change in absorbance is directly proportional to the rate of PPI production and thus to the GGPPS activity.
 - Kinetic parameters can be determined by measuring the initial reaction rates at various substrate concentrations.

3. LC-MS/MS-Based Assay

Liquid chromatography-tandem mass spectrometry (LC-MS/MS) offers a highly specific and sensitive method for the direct detection and quantification of the reaction products.[\[12\]](#)[\[13\]](#)

- Materials and Reagents:
 - Purified GGPPS isoform

- Allylic substrates (DMAPP, GPP, FPP) and IPP
- Reaction Buffer: 50 mM Tris-HCl (pH 7.5), 5 mM MgCl₂, 2 mM DTT
- Quenching Solution: Cold methanol or EDTA solution
- LC-MS/MS system
- Procedure:
 - Perform the enzymatic reaction as described for the radiochemical assay (using non-radiolabeled substrates).
 - Terminate the reaction by adding a quenching solution.
 - Centrifuge the samples to pellet the enzyme and any precipitate.
 - Inject a specific volume of the supernatant into the LC-MS/MS system.
 - Separate the products (GPP, FPP, GGPP) using a suitable liquid chromatography method (e.g., reverse-phase chromatography).
 - Detect and quantify the products using tandem mass spectrometry in multiple reaction monitoring (MRM) mode, which provides high specificity.
 - Create a standard curve with known concentrations of the products to accurately quantify the amount of product formed in the enzymatic reaction.
 - Determine kinetic parameters by analyzing product formation at different substrate concentrations.

Visualizing Pathways and Workflows

Isoprenoid Biosynthesis Pathway

The following diagram illustrates the central role of GGPPS in the isoprenoid biosynthesis pathway.

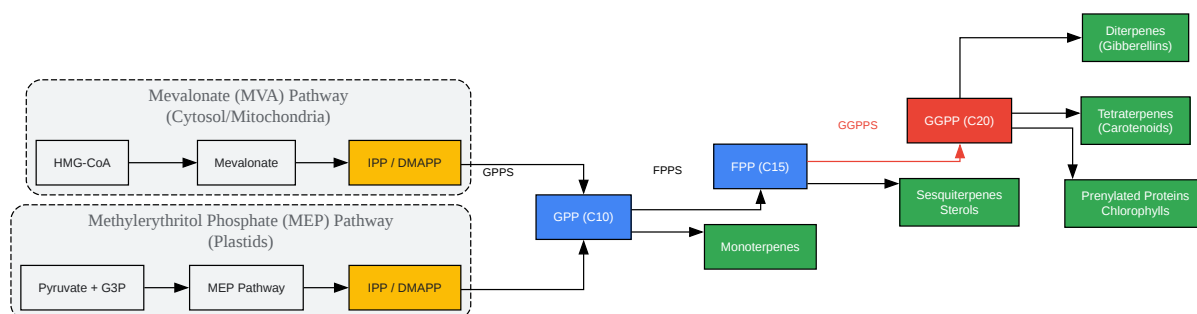

[Click to download full resolution via product page](#)

Caption: The central role of GGPPS in the isoprenoid biosynthesis pathway.

General Experimental Workflow for GGPPS Kinetic Analysis

This diagram outlines the typical steps involved in determining the kinetic parameters of a GGPPS isoform.

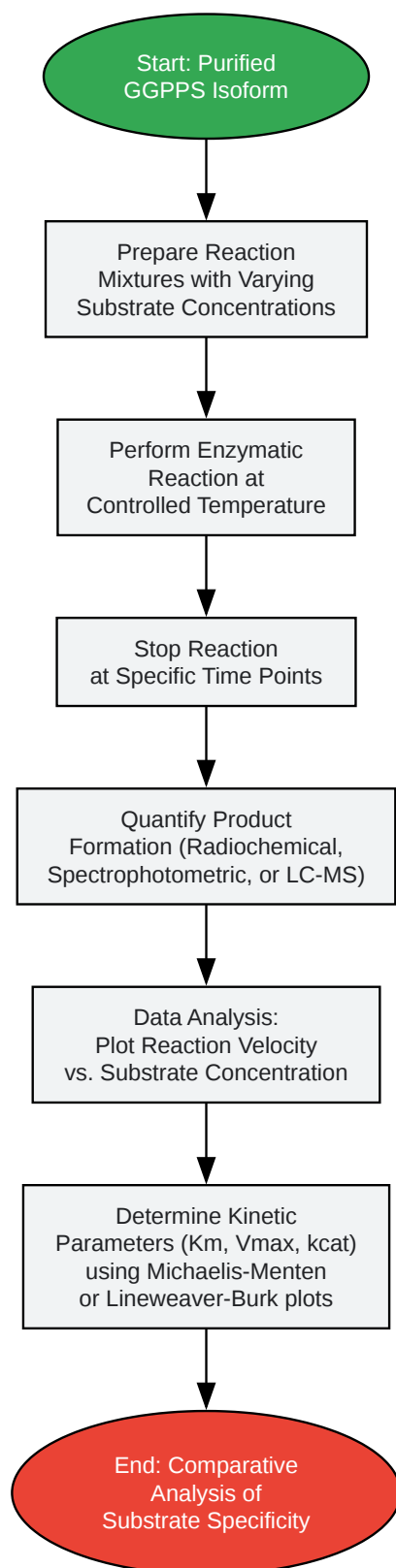

[Click to download full resolution via product page](#)

Caption: A generalized workflow for the kinetic analysis of GGPPS isoforms.

Discussion and Conclusion

The substrate specificity of GGPPS isoforms is a complex and crucial aspect of their biological function. As the data indicates, different isoforms can exhibit varying affinities for their allylic and isoprenyl pyrophosphate substrates. For instance, the bovine brain GGPPS shows a high affinity for FPP and GPP, suggesting it primarily acts on these intermediates.[6] In plants, the formation of heterodimers can significantly alter the kinetic properties of the enzyme, as seen with the OsGGPPS1 from rice, where interaction with another protein subunit increases its affinity for IPP.[1]

The choice of experimental method for characterizing GGPPS isoforms depends on the specific research question and available resources. Radiochemical assays offer high sensitivity, while spectrophotometric methods allow for continuous monitoring of the reaction. LC-MS/MS provides unparalleled specificity and the ability to detect multiple products simultaneously.

For researchers in drug development, understanding the subtle differences in substrate specificity between, for example, human GGPPS and that of a pathogen could open avenues for the design of selective inhibitors. For scientists in metabolic engineering, knowledge of isoform kinetics is essential for optimizing the production of valuable isoprenoids in microbial or plant systems.

In conclusion, the comparative analysis of GGPPS isoform substrate specificity, supported by robust experimental data, is fundamental to advancing our understanding of isoprenoid metabolism and its applications in biotechnology and medicine. Further research is needed to fully characterize the kinetic parameters of a wider range of GGPPS isoforms from diverse organisms.

Need Custom Synthesis?

BenchChem offers custom synthesis for rare earth carbides and specific isotopic labeling.

Email: info@benchchem.com or [Request Quote Online](#).

References

- 1. A recruiting protein of geranylgeranyl diphosphate synthase controls metabolic flux toward chlorophyll biosynthesis in rice - PMC [pmc.ncbi.nlm.nih.gov]

- 2. Plant geranylgeranyl diphosphate synthases: every (gene) family has a story - PMC [[pmc.ncbi.nlm.nih.gov](https://pubmed.ncbi.nlm.nih.gov)]
- 3. Molecular mechanisms linking geranylgeranyl diphosphate synthase to cell survival and proliferation - PMC [[pmc.ncbi.nlm.nih.gov](https://pubmed.ncbi.nlm.nih.gov)]
- 4. Frontiers | Distinct evolutionary strategies in the GGPPS family from plants [frontiersin.org]
- 5. academic.oup.com [academic.oup.com]
- 6. Purification of geranylgeranyl diphosphate synthase from bovine brain - PubMed [pubmed.ncbi.nlm.nih.gov]
- 7. Several geranylgeranyl diphosphate synthase isoforms supply metabolic substrates for carotenoid biosynthesis in tomato - PubMed [pubmed.ncbi.nlm.nih.gov]
- 8. A cytosolic bifunctional geranyl/farnesyl diphosphate synthase provides MVA-derived GPP for geraniol biosynthesis in rose flowers - PMC [[pmc.ncbi.nlm.nih.gov](https://pubmed.ncbi.nlm.nih.gov)]
- 9. benchchem.com [benchchem.com]
- 10. A Simple In Vitro Assay to Measure the Activity of Geranylgeranyl Diphosphate Synthase and Other Short-Chain Prenyltransferases - PubMed [pubmed.ncbi.nlm.nih.gov]
- 11. A Simple In Vitro Assay to Measure the Activity of Geranylgeranyl Diphosphate Synthase and Other Short-Chain Prenyltransferases | Springer Nature Experiments [experiments.springernature.com]
- 12. researchgate.net [researchgate.net]
- 13. A quantitative method to measure geranylgeranyl diphosphate (GGPP) and geranylgeranyl monophosphate (GPP) in tomato (*Solanum lycopersicum*) fruit - PMC [[pmc.ncbi.nlm.nih.gov](https://pubmed.ncbi.nlm.nih.gov)]
- To cite this document: BenchChem. [A Comparative Guide to the Substrate Specificity of GGPPS Isoforms]. BenchChem, [2025]. [Online PDF]. Available at: [<https://www.benchchem.com/product/b1195527#comparing-the-substrate-specificity-of-different-ggpps-isoforms>]

Disclaimer & Data Validity:

The information provided in this document is for Research Use Only (RUO) and is strictly not intended for diagnostic or therapeutic procedures. While BenchChem strives to provide accurate protocols, we make no warranties, express or implied, regarding the fitness of this product for every specific experimental setup.

Technical Support: The protocols provided are for reference purposes. Unsure if this reagent suits your experiment? [[Contact our Ph.D. Support Team for a compatibility check](#)]

Need Industrial/Bulk Grade? [Request Custom Synthesis Quote](#)

BenchChem

Our mission is to be the trusted global source of essential and advanced chemicals, empowering scientists and researchers to drive progress in science and industry.

Contact

Address: 3281 E Guasti Rd

Ontario, CA 91761, United States

Phone: (601) 213-4426

Email: info@benchchem.com