

A Comparative Guide to the Molecular Targets of MP07-66 and FTY720

Author: BenchChem Technical Support Team. **Date:** December 2025

Compound of Interest

Compound Name: MP07-66

Cat. No.: B8229418

[Get Quote](#)

For Researchers, Scientists, and Drug Development Professionals

This guide provides a detailed, objective comparison of the molecular targets of two structurally related compounds, **MP07-66** and FTY720 (Fingolimod). While both are analogs of the natural sphingolipid metabolite myriocin, their distinct molecular interactions lead to different biological outcomes. This document summarizes key quantitative data, outlines experimental methodologies for target validation, and visualizes the signaling pathways involved.

Executive Summary

FTY720 (Gilenya®), a first-in-class oral therapy for relapsing-remitting multiple sclerosis, is a prodrug that, upon phosphorylation, acts as a potent modulator of sphingosine-1-phosphate (S1P) receptors, leading to immunosuppression by sequestering lymphocytes in lymph nodes. [1][2] Beyond its well-characterized effects on S1P receptors, FTY720 and its phosphorylated form (FTY720-P) have been shown to interact with other molecular targets, including protein phosphatase 2A (PP2A), sphingosine kinase 1 (SK1), and ceramide synthases (CerS), contributing to its anti-cancer properties. [3][4]

MP07-66 is a non-immunosuppressive analog of FTY720 designed to minimize S1P receptor activity and leverage alternative signaling pathways. [1][5][6] Its primary molecular target is the SET-PP2A complex, where it functions as a PP2A activator, inducing apoptosis in cancer cells. [1][6] Furthermore, **MP07-66** indirectly activates the tyrosine phosphatase SHP-1, expanding its potential as a therapeutic agent in oncology. [1][3][5]

Data Presentation: Quantitative Comparison of Molecular Interactions

The following tables summarize the available quantitative data for the interaction of **MP07-66** and FTY720 with their respective molecular targets.

Table 1: **MP07-66** Molecular Target Interactions

Target	Parameter	Value	Cell/System	Reference
SET-PP2A	Apoptosis Induction	8 μ M (induces apoptosis)	Chronic Lymphocytic Leukemia (CLL) cells	[5][7]
SHP-1	Activation	8 μ M (induces activation)	Chronic Lymphocytic Leukemia (CLL) cells	[1][5]

Table 2: FTY720 and FTY720-P Molecular Target Interactions

Compound	Target	Parameter	Value	Cell/System	Reference
FTY720-P	S1P1 Receptor	EC50	0.3 nM	CHO cells	[8]
FTY720-P	S1P3 Receptor	EC50	0.35 nM	CHO cells	[8]
FTY720-P	S1P4 Receptor	EC50	0.55 nM	CHO cells	[8]
FTY720-P	S1P5 Receptor	EC50	0.2 nM	CHO cells	[8]
FTY720	Sphingosine Kinase 1 (SK1)	IC50	~50 μ M	Purified enzyme	[3]
FTY720	Ceramide Synthase 2 (CerS2)	IC50	6.4 μ M	Human pulmonary artery endothelial cell lysate	[9][10]
FTY720	Ceramide Synthase 2 (CerS2)	Ki	2.15 μ M	Human pulmonary artery endothelial cell lysate	[10]
FTY720	PP2A	Activation	3 μ M (induces activation)	Breast cancer cell lines	

Signaling Pathways

The distinct molecular targets of **MP07-66** and FTY720 initiate different downstream signaling cascades.

MP07-66 Signaling Pathway

MP07-66 primarily acts by disrupting the inhibitory interaction between SET and the catalytic subunit of PP2A. This leads to the reactivation of PP2A, a serine/threonine phosphatase that acts as a tumor suppressor by dephosphorylating key proteins involved in cell growth and survival pathways, such as Akt and ERK.[1][5] Activated PP2A also dephosphorylates and activates the tyrosine phosphatase SHP-1, which can further contribute to the pro-apoptotic effects of **MP07-66**. [1][3][5]

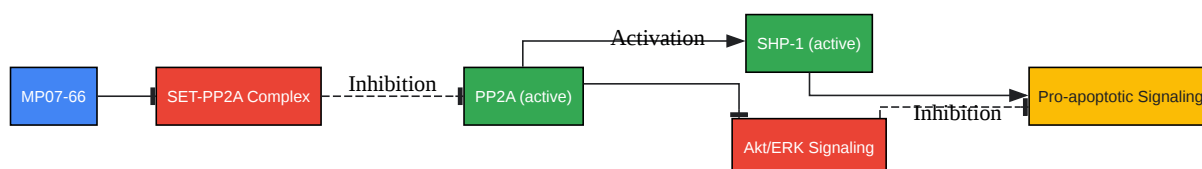

[Click to download full resolution via product page](#)

MP07-66 induced signaling cascade.

FTY720 Signaling Pathway

FTY720 is a prodrug that is phosphorylated in vivo to FTY720-phosphate (FTY720-P). FTY720-P is a potent agonist at four of the five S1P receptors (S1P1, S1P3, S1P4, and S1P5). The binding of FTY720-P to the S1P1 receptor on lymphocytes leads to receptor internalization and degradation, effectively acting as a functional antagonist and preventing lymphocyte egress from lymph nodes.[2] This is the primary mechanism for its immunosuppressive effects. Additionally, non-phosphorylated FTY720 can inhibit SK1 and CerS, and both FTY720 and FTY720-P can activate PP2A, contributing to its anti-cancer activities.[3][4][10]

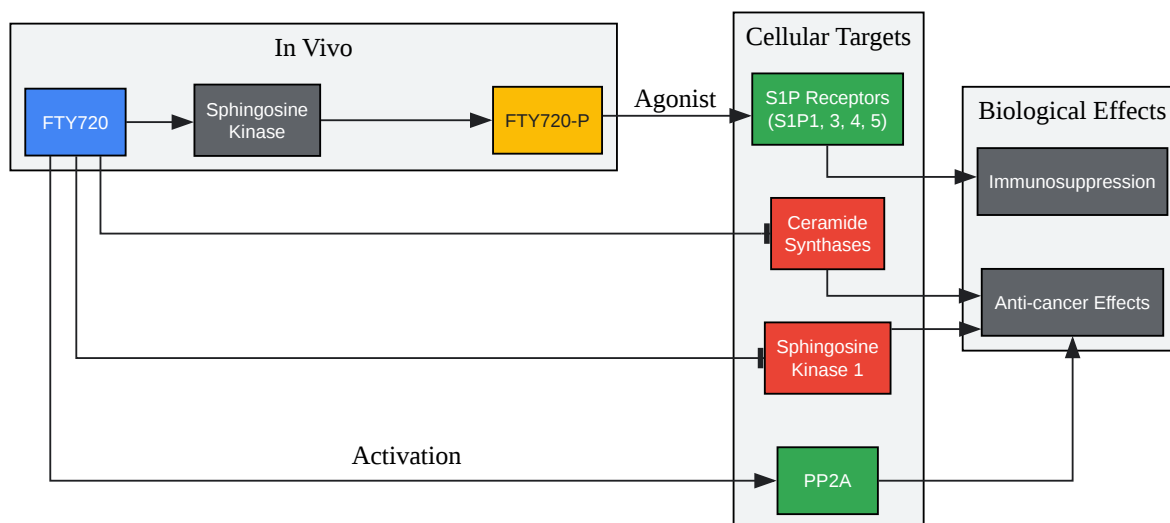

[Click to download full resolution via product page](#)

FTY720 mechanism of action.

Experimental Protocols

This section provides an overview of the methodologies used to characterize the interactions of **MP07-66** and FTY720 with their molecular targets.

PP2A Activity Assay (for MP07-66 and FTY720)

This assay measures the ability of a compound to activate PP2A by quantifying the dephosphorylation of a synthetic phosphopeptide substrate.

Workflow:

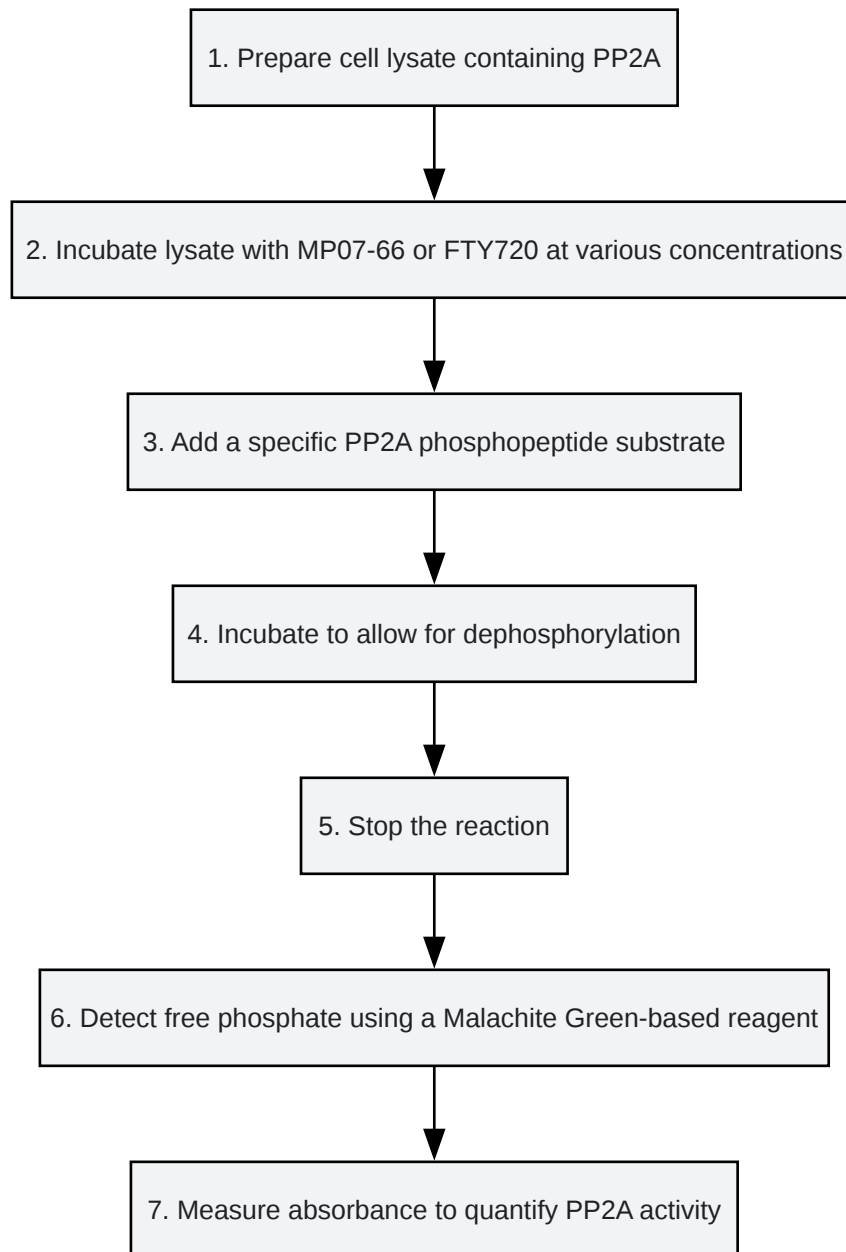

[Click to download full resolution via product page](#)

PP2A activity assay workflow.

Detailed Method:

- Cell Lysate Preparation: Cells of interest are lysed in a buffer that preserves phosphatase activity.

- **Compound Incubation:** The cell lysate is incubated with varying concentrations of the test compound (**MP07-66** or FTY720) to allow for interaction with the SET-PP2A complex.
- **Substrate Addition:** A synthetic phosphopeptide, a known substrate for PP2A (e.g., K-R-pT-I-R-R), is added to the reaction mixture.
- **Dephosphorylation Reaction:** The mixture is incubated at 37°C to allow PP2A to dephosphorylate the substrate.
- **Reaction Termination:** The reaction is stopped by the addition of a quenching solution.
- **Phosphate Detection:** A Malachite Green-based reagent is added, which forms a colored complex with the free phosphate released during the reaction.
- **Quantification:** The absorbance of the colored complex is measured using a spectrophotometer, and the amount of free phosphate is determined from a standard curve. This is directly proportional to the PP2A activity.

SHP-1 Phosphatase Activity Assay (for MP07-66)

This assay determines the effect of **MP07-66** on the catalytic activity of the tyrosine phosphatase SHP-1.

Workflow:

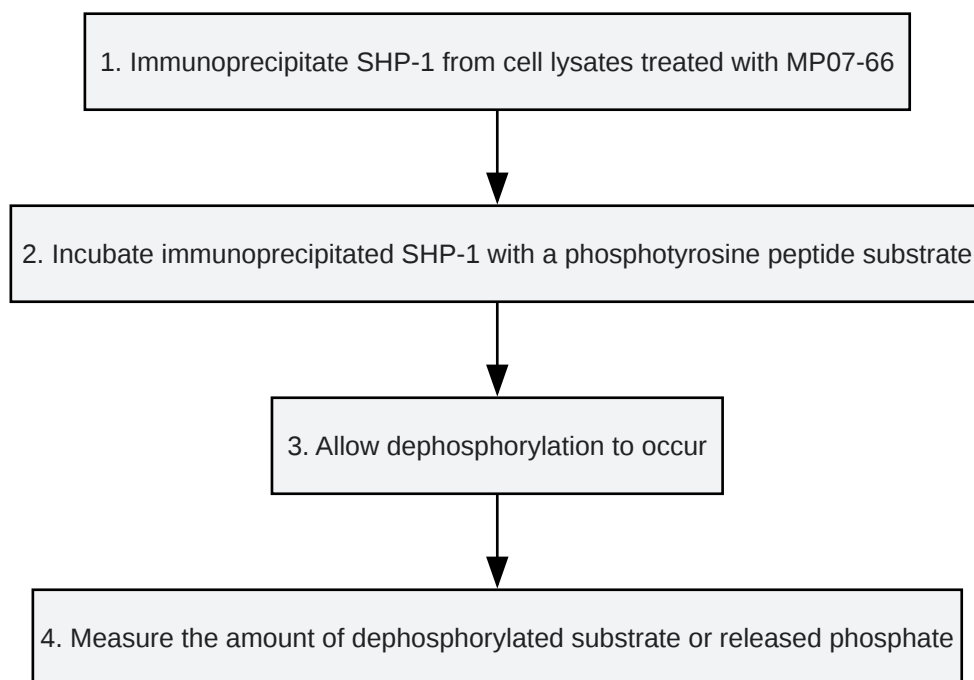

[Click to download full resolution via product page](#)

SHP-1 phosphatase assay workflow.

Detailed Method:

- SHP-1 Immunoprecipitation: SHP-1 is isolated from cell lysates (previously treated with or without **MP07-66**) using an anti-SHP-1 antibody coupled to agarose beads.[1][5]
- Substrate Incubation: The immunoprecipitated SHP-1 is incubated with a synthetic phosphotyrosine-containing substrate (e.g., pNPP or a specific peptide).
- Dephosphorylation: The reaction is allowed to proceed at 37°C.
- Detection: The phosphatase activity is quantified by measuring the amount of product formed (e.g., p-nitrophenol from pNPP) or by using a specific antibody that recognizes the dephosphorylated substrate.

S1P Receptor Binding Assay (for FTY720-P)

This assay measures the affinity of FTY720-P for different S1P receptor subtypes.

Workflow:

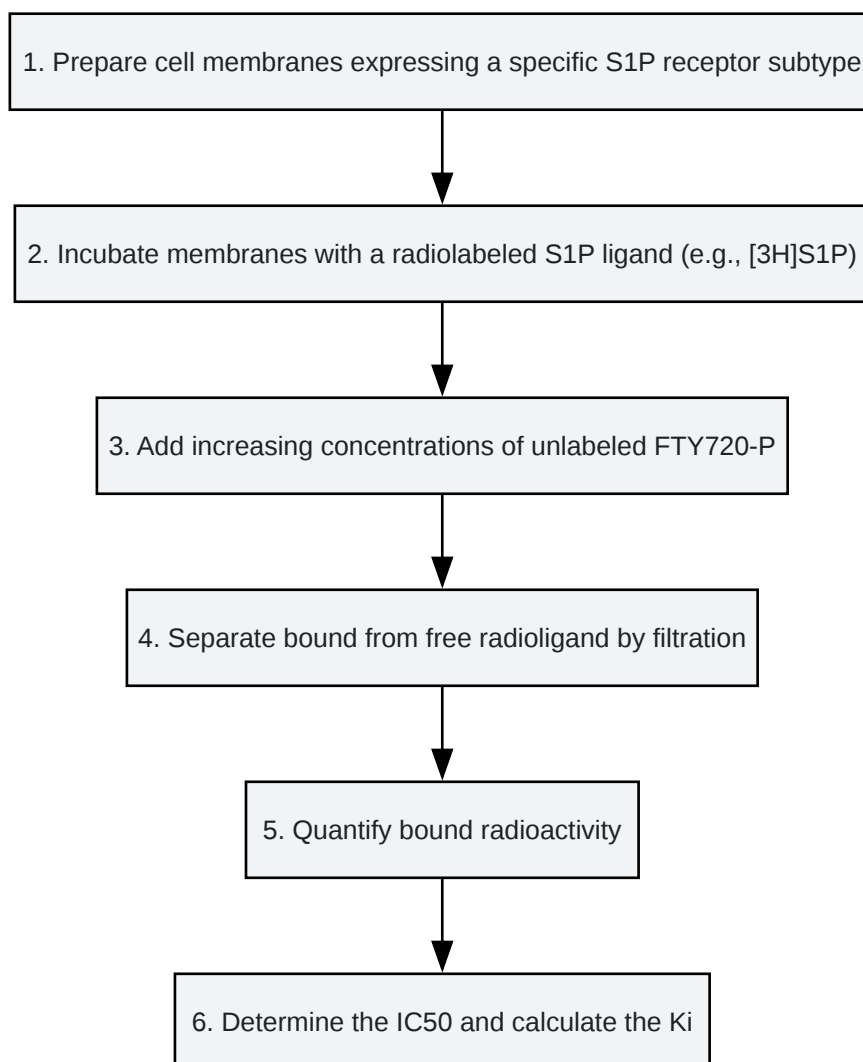

[Click to download full resolution via product page](#)

S1P receptor binding assay workflow.

Detailed Method:

- Membrane Preparation: Cell lines overexpressing a specific S1P receptor subtype are cultured and their membranes are isolated.
- Radioligand Incubation: The membranes are incubated with a constant concentration of a radiolabeled S1P analog.
- Competitive Binding: Increasing concentrations of unlabeled FTY720-P are added to compete with the radioligand for binding to the receptor.

- Separation: The reaction mixture is filtered to separate the membrane-bound radioligand from the unbound radioligand.
- Quantification: The amount of radioactivity retained on the filter is measured using a scintillation counter.
- Data Analysis: The data is used to generate a competition curve, from which the IC₅₀ (the concentration of FTY720-P that inhibits 50% of the specific binding of the radioligand) is determined. The binding affinity (K_i) can then be calculated using the Cheng-Prusoff equation.

Conclusion

MP07-66 and FTY720, despite their structural similarities, exhibit distinct molecular targeting profiles that translate into different pharmacological activities. FTY720's primary immunosuppressive action is mediated through its functional antagonism of S1P receptors, while its anti-cancer effects are attributed to a broader range of targets including PP2A, SK1, and CerS. In contrast, **MP07-66** is a more targeted agent, designed to be non-immunosuppressive by minimizing S1P receptor interaction. Its primary mechanism of action is the activation of the PP2A/SHP-1 phosphatase axis, making it a promising candidate for cancer therapy. This guide provides a foundational understanding of the molecular basis of action for these two compounds, which is crucial for researchers and clinicians in the fields of immunology and oncology. Further studies are warranted to fully elucidate the quantitative aspects of **MP07-66**'s interaction with its targets and to explore the full therapeutic potential of both molecules.

Need Custom Synthesis?

BenchChem offers custom synthesis for rare earth carbides and specific isotopic labeling.

Email: info@benchchem.com or [Request Quote Online](#).

References

1. Targeted activation of the SHP-1/PP2A signaling axis elicits apoptosis of chronic lymphocytic leukemia cells - PMC [pmc.ncbi.nlm.nih.gov]

- 2. Targeted activation of the SHP-1/PP2A signaling axis elicits apoptosis of chronic lymphocytic leukemia cells - PubMed [pubmed.ncbi.nlm.nih.gov]
- 3. Targeted activation of the SHP-1/PP2A signaling axis elicits apoptosis of chronic lymphocytic leukemia cells | Haematologica [haematologica.org]
- 4. selleckchem.com [selleckchem.com]
- 5. haematologica.org [haematologica.org]
- 6. researchgate.net [researchgate.net]
- 7. FTY720 Inhibits Ceramide Synthases and Up-regulates Dihydrosphingosine 1-Phosphate Formation in Human Lung Endothelial Cells - PMC [pmc.ncbi.nlm.nih.gov]
- 8. FTY720 inhibits ceramide synthases and up-regulates dihydrosphingosine 1-phosphate formation in human lung endothelial cells - PubMed [pubmed.ncbi.nlm.nih.gov]
- 9. A practical process for the preparation of [32P]S1P and binding assay for S1P receptor ligands - PMC [pmc.ncbi.nlm.nih.gov]
- 10. merckmillipore.com [merckmillipore.com]
- To cite this document: BenchChem. [A Comparative Guide to the Molecular Targets of MP07-66 and FTY720]. BenchChem, [2025]. [Online PDF]. Available at: [https://www.benchchem.com/product/b8229418#comparing-the-molecular-targets-of-mp07-66-and-fty720]

Disclaimer & Data Validity:

The information provided in this document is for Research Use Only (RUO) and is strictly not intended for diagnostic or therapeutic procedures. While BenchChem strives to provide accurate protocols, we make no warranties, express or implied, regarding the fitness of this product for every specific experimental setup.

Technical Support: The protocols provided are for reference purposes. Unsure if this reagent suits your experiment? [[Contact our Ph.D. Support Team for a compatibility check](#)]

Need Industrial/Bulk Grade? [Request Custom Synthesis Quote](#)

BenchChem

Our mission is to be the trusted global source of essential and advanced chemicals, empowering scientists and researchers to drive progress in science and industry.

Contact

Address: 3281 E Guasti Rd

Ontario, CA 91761, United States

Phone: (601) 213-4426

Email: info@benchchem.com