

A Comparative Guide to Tributyl Phosphite and Other Phosphite Antioxidants

Author: BenchChem Technical Support Team. **Date:** December 2025

Compound of Interest

Compound Name: Tributyl phosphite

Cat. No.: B1683024

[Get Quote](#)

For Researchers, Scientists, and Drug Development Professionals

This guide provides an objective comparison of **tributyl phosphite** with other common phosphite antioxidants used in polymer stabilization and other applications requiring protection from oxidative degradation. Phosphite antioxidants, also known as secondary antioxidants, play a critical role by decomposing hydroperoxides, which are key intermediates in the auto-oxidation cycle of organic materials.[1] The selection of a specific phosphite is crucial as it impacts thermal stability, hydrolytic stability, color retention, and overall material longevity.

The effectiveness and properties of a phosphite antioxidant are largely determined by the nature of the organic groups (R) attached to the $P(OR)_3$ molecule. These can be broadly categorized into simple alkyl phosphites, like **tributyl phosphite**, and aryl phosphites, such as triphenyl phosphite and more sterically hindered variants like Tris(2,4-di-tert-butylphenyl)phosphite (e.g., Irgafos 168).

Performance and Properties Comparison

The following table summarizes the key properties and general performance characteristics of **tributyl phosphite** compared to representative aryl phosphites. While extensive quantitative performance data for hindered aryl phosphites is widely published, specific comparative data for simple alkyl phosphites like **tributyl phosphite** in polymer applications is less common. The performance characteristics below are based on established chemical principles of these compound classes.[1][2]

Property	Tributyl Phosphite (Alkyl)	Triphenyl Phosphite (Aryl)	Tris(2,4-di-tert-butylphenyl)phosphite (Hindered Aryl)
CAS Number	102-85-2[3][4]	101-02-0[3]	31570-04-4[5]
Molecular Formula	C ₁₂ H ₂₇ O ₃ P[3][4]	C ₁₈ H ₁₅ O ₃ P[3]	C ₄₂ H ₆₃ O ₃ P[5]
Molecular Weight	250.32 g/mol [4][6]	310.3 g/mol [3]	646.9 g/mol [5]
Phosphorus Content	~12.4%	~10.0%[3]	~4.8%
Physical Form	Colorless Liquid[4]	Colorless Liquid/Solid[3]	White Crystalline Powder[5]
Melting Point	-80 °C[4]	19 - 24 °C[3]	183 - 187 °C[5]
Boiling Point	~265 °C[3]	360 °C[3]	N/A (Decomposes)
Reactivity	High reactivity in hydroperoxide decomposition.[1]	Moderate reactivity.	Lower reactivity due to steric hindrance.[1]
Thermal Stability	Lower; more volatile. [7]	Moderate.	Excellent; low volatility due to high molecular weight.[8][9]
Hydrolytic Stability	Low; sensitive to moisture.[3][10]	Moderate.	Excellent, due to bulky tert-butyl groups protecting the phosphorus atom.[2][5]
Color Stability	Good initial color.	Good; often used to prevent color changes in PVC.[11]	Excellent; widely used to inhibit discoloration. [12]
Primary Applications	PVC stabilizer, chemical synthesis reagent.[3][4]	PVC, polyolefins, epoxy resins, polyesters.[3][11]	High-performance polymers (PE, PP), food-contact applications.[9][13]

Summary of Comparison:

- **Tributyl Phosphite (TBP)**: As a simple alkyl phosphite, TBP is a liquid with a high phosphorus content and high reactivity, making it an effective hydroperoxide decomposer.[1] However, its utility is often limited by its lower thermal stability, higher volatility, and poor hydrolytic stability, making it susceptible to degradation in the presence of moisture.[3][7][10]
- **Triphenyl Phosphite (TPP)**: This aryl phosphite offers a balance of properties with better thermal stability than TBP.[3][11] It is widely used as a stabilizer and chelating agent, particularly in PVC applications, to maintain clarity and prevent discoloration.[11]
- **Tris(2,4-di-tert-butylphenyl)phosphite (e.g., Irgafos 168)**: This high-molecular-weight, sterically hindered aryl phosphite is a benchmark for high-performance applications.[9] The bulky tert-butyl groups provide exceptional thermal and hydrolytic stability, making it highly resistant to degradation during high-temperature processing and long-term use.[5][8] While its reactivity is lower than simple alkyl phosphites, its superior stability and low volatility ensure it remains effective in the polymer matrix.[1][9]

Mechanisms and Experimental Workflows

The following diagrams illustrate the fundamental antioxidant mechanism of phosphites and a standard workflow for evaluating their performance.

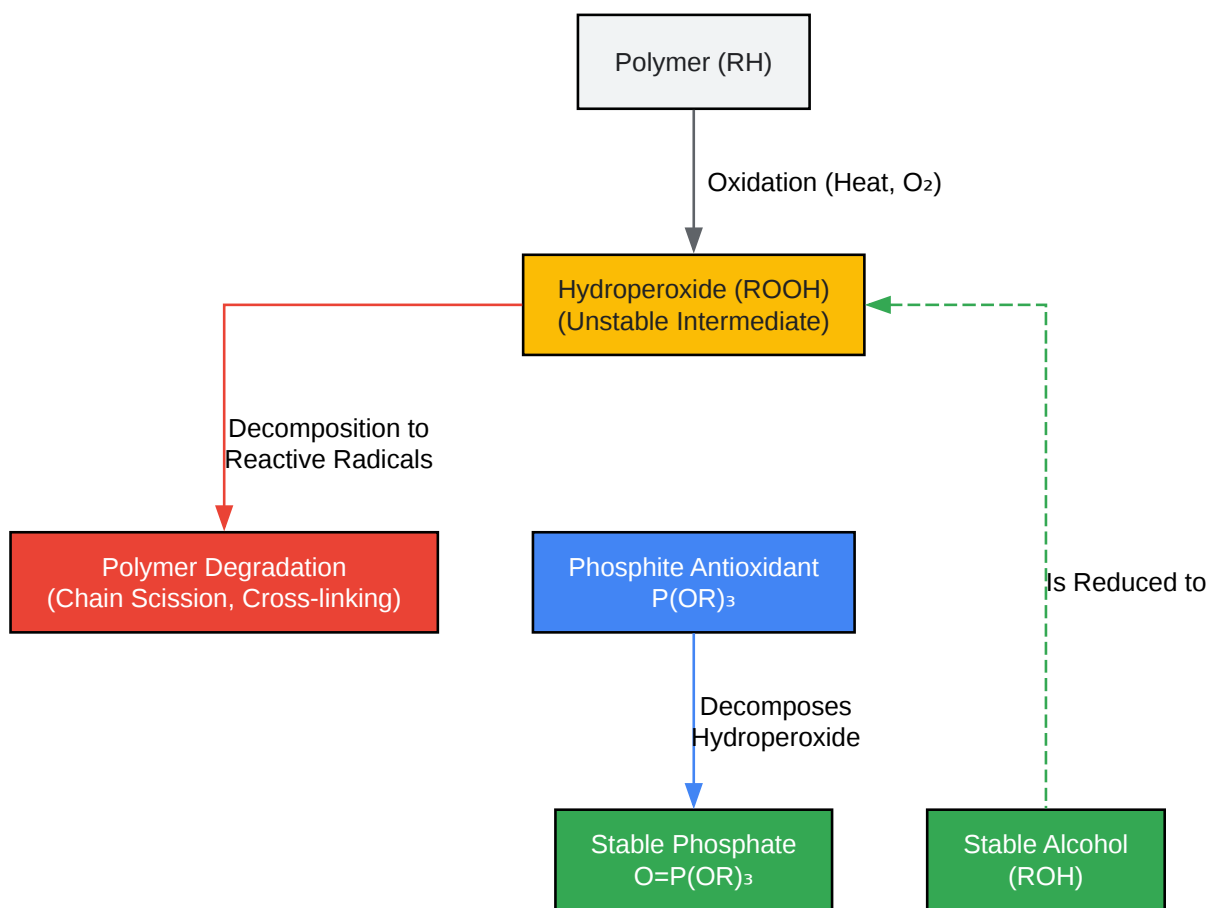

[Click to download full resolution via product page](#)

Caption: Mechanism of polymer stabilization by phosphite antioxidants.

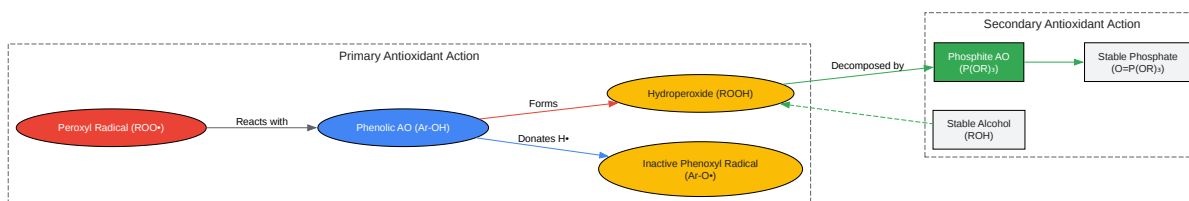

[Click to download full resolution via product page](#)

Caption: Synergistic antioxidant mechanism of phenolics and phosphites.

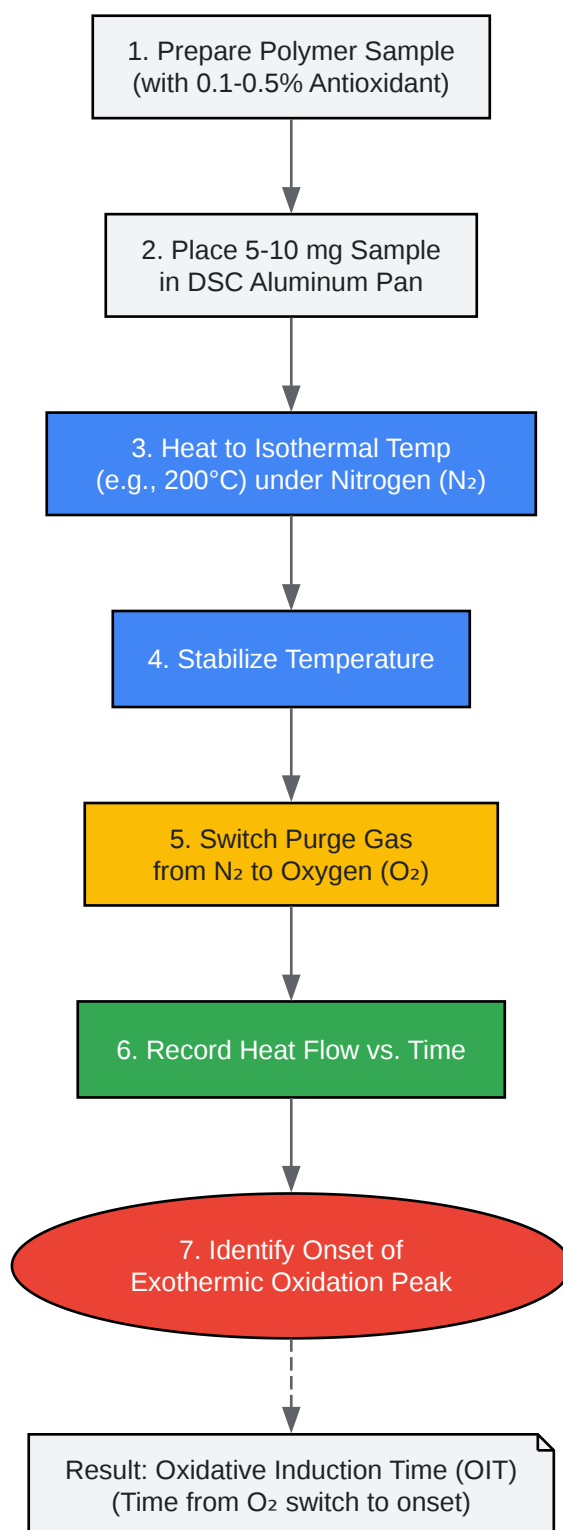

[Click to download full resolution via product page](#)

Caption: Experimental workflow for Oxidative Induction Time (OIT) testing.

Experimental Protocols

Detailed methodologies for assessing the performance of phosphite antioxidants are provided below.

This method is a standard for evaluating the thermo-oxidative stability of a polymer stabilized with an antioxidant.^{[1][14]}

- Principle: A polymer sample containing the antioxidant is heated to a high, constant temperature in an inert atmosphere. Oxygen is then introduced, and the time until the onset of exothermic oxidation is measured. A longer OIT indicates better thermal stability.^{[15][16]}
- Apparatus: Differential Scanning Calorimeter (DSC).
- Procedure:
 - A sample of the polymer stabilized with a known concentration of the phosphite antioxidant (typically 0.1-0.5% by weight) is prepared.^[14]
 - A small, known weight of the sample (5-10 mg) is placed into an aluminum DSC pan.^[14]
 - The pan is placed in the DSC cell, which is then sealed.
 - The sample is heated to the desired isothermal test temperature (e.g., 200°C for polypropylene) under a continuous nitrogen purge.^{[14][15]}
 - Once the temperature has stabilized and the heat flow is constant, the purge gas is switched from nitrogen to oxygen at the same flow rate.^{[14][15]}
 - The heat flow is recorded as a function of time.
 - The OIT is determined as the time elapsed from the introduction of oxygen to the onset of the sharp exothermic peak, which signifies the start of rapid oxidation.^[14]

This test assesses the susceptibility of a phosphite antioxidant to hydrolysis, which can diminish its effectiveness.[1][14]

- Principle: The antioxidant is exposed to controlled conditions of high temperature and humidity. Its degradation is monitored over time by quantifying the amount of unhydrolyzed phosphite remaining.
- Apparatus: Humidity chamber, High-Performance Liquid Chromatography (HPLC) system.
- Procedure:
 - A known quantity of the pure phosphite antioxidant is placed in a shallow, open container (e.g., a glass petri dish).[14]
 - The container is placed inside a humidity chamber set to a specific temperature and relative humidity (e.g., 80°C and 85% RH).[14]
 - Samples of the antioxidant are removed from the chamber at predetermined time intervals (e.g., 24, 48, 72 hours).
 - Each removed sample is dissolved in a suitable solvent and analyzed by HPLC.
 - The HPLC analysis quantifies the concentration of the remaining, unhydrolyzed phosphite antioxidant.
 - The hydrolytic stability is reported as the percentage of active phosphite remaining as a function of exposure time.

This method evaluates the ability of an antioxidant to prevent discoloration (e.g., yellowing) of a polymer during processing and aging.

- Principle: The color of a polymer sample containing the antioxidant is measured before and after being subjected to heat or UV aging. The change in color, often expressed as the Yellowness Index (YI), is calculated.
- Apparatus: Colorimeter or spectrophotometer, laboratory oven or UV weathering chamber.
- Procedure:

- Polymer plaques or films are prepared with a defined concentration of the antioxidant.
- The initial color of the samples is measured using a colorimeter, which records the CIELAB color space values (L, a, b*).
- The samples are then placed in an oven at an elevated temperature (e.g., 85°C) or in a UV weathering chamber for a specified duration to simulate aging.
- After the aging period, the samples are removed and their color is measured again.
- The Yellowness Index (YI) is calculated from the L, a, and b* values according to standard methods (e.g., ASTM E313). A smaller change in YI indicates better color stability.

Need Custom Synthesis?

BenchChem offers custom synthesis for rare earth carbides and specific isotopic labeling.

Email: info@benchchem.com or [Request Quote Online](#).

References

- 1. benchchem.com [benchchem.com]
- 2. life-trialkyl.eu [life-trialkyl.eu]
- 3. Page loading... [guidechem.com]
- 4. chemimpex.com [chemimpex.com]
- 5. welltchemicals.com [welltchemicals.com]
- 6. Tributyl phosphite | C12H27O3P | CID 7623 - PubChem [pubchem.ncbi.nlm.nih.gov]
- 7. bdmaee.net [bdmaee.net]
- 8. ohans.com [ohans.com]
- 9. nbinno.com [nbinno.com]
- 10. TRIBUTYL PHOSPHITE | 102-85-2 [chemicalbook.com]
- 11. Triphenyl phosphite Seven Chongqing Chemdad Co. , Ltd [chemdad.com]
- 12. Tris 2 4 Di Tert Butylphenyl Phosphite, Phosphite Antioxidant Manufacturer | Tintoll [uvabsorber.com]

- 13. Safety assessment for Tris(2,4-di-tert-butylphenyl) phosphite (Irgafos 168) used as an antioxidant and stabilizer in food contact applications - PubMed [pubmed.ncbi.nlm.nih.gov]
- 14. benchchem.com [benchchem.com]
- 15. mdpi.com [mdpi.com]
- 16. researchgate.net [researchgate.net]
- To cite this document: BenchChem. [A Comparative Guide to Tributyl Phosphite and Other Phosphite Antioxidants]. BenchChem, [2025]. [Online PDF]. Available at: [https://www.benchchem.com/product/b1683024#comparing-tributyl-phosphite-with-other-phosphite-antioxidants]

Disclaimer & Data Validity:

The information provided in this document is for Research Use Only (RUO) and is strictly not intended for diagnostic or therapeutic procedures. While BenchChem strives to provide accurate protocols, we make no warranties, express or implied, regarding the fitness of this product for every specific experimental setup.

Technical Support: The protocols provided are for reference purposes. Unsure if this reagent suits your experiment? [[Contact our Ph.D. Support Team for a compatibility check](#)]

Need Industrial/Bulk Grade? [Request Custom Synthesis Quote](#)

BenchChem

Our mission is to be the trusted global source of essential and advanced chemicals, empowering scientists and researchers to drive progress in science and industry.

Contact

Address: 3281 E Guasti Rd
Ontario, CA 91761, United States
Phone: (601) 213-4426
Email: info@benchchem.com