

# A Comparative Guide to SGK1 Inhibitors: SI113 vs. Alternatives

**Author:** BenchChem Technical Support Team. **Date:** December 2025

## Compound of Interest

Compound Name: SI113

Cat. No.: B610833

[Get Quote](#)

For researchers, scientists, and drug development professionals, this guide provides an objective comparison of the SGK1 inhibitor **SI113** with other commercially available or widely studied alternatives, GSK650394 and EMD638683. The information is presented to assist in the selection of the most appropriate inhibitor for specific research needs, with supporting experimental data and detailed methodologies.

Serum and glucocorticoid-regulated kinase 1 (SGK1) is a serine/threonine kinase that plays a crucial role in various cellular processes, including cell survival, proliferation, and ion channel regulation. Its dysregulation has been implicated in several diseases, most notably in cancer and hypertension, making it an attractive target for therapeutic intervention. A number of small molecule inhibitors have been developed to target SGK1. This guide focuses on a comparative analysis of **SI113**, a pyrazolo[3,4-d]pyrimidine-based inhibitor, against two other well-characterized SGK1 inhibitors, GSK650394 and EMD638683.

## Quantitative Comparison of SGK1 Inhibitors

The following table summarizes the key quantitative data for **SI113**, GSK650394, and EMD638683, focusing on their potency and selectivity against SGK isoforms.

Inhibitor	Target	IC50	Selectivity
SI113	SGK1	600 nM[1][2]	Selective for SGK1 over c-Src and Abl kinases at 12.5 $\mu$ M.[3] 100-fold more selective for SGK1 than for AKT1 (IC50 ~50 $\mu$ M).[4]
GSK650394	SGK1	62 nM[5]	Also inhibits SGK2 with an IC50 of 103 nM.[5]
EMD638683	SGK1	3 $\mu$ M[2]	-

## Signaling Pathways and Experimental Workflows

To visualize the mechanism of action and the experimental approaches used to evaluate these inhibitors, the following diagrams are provided.

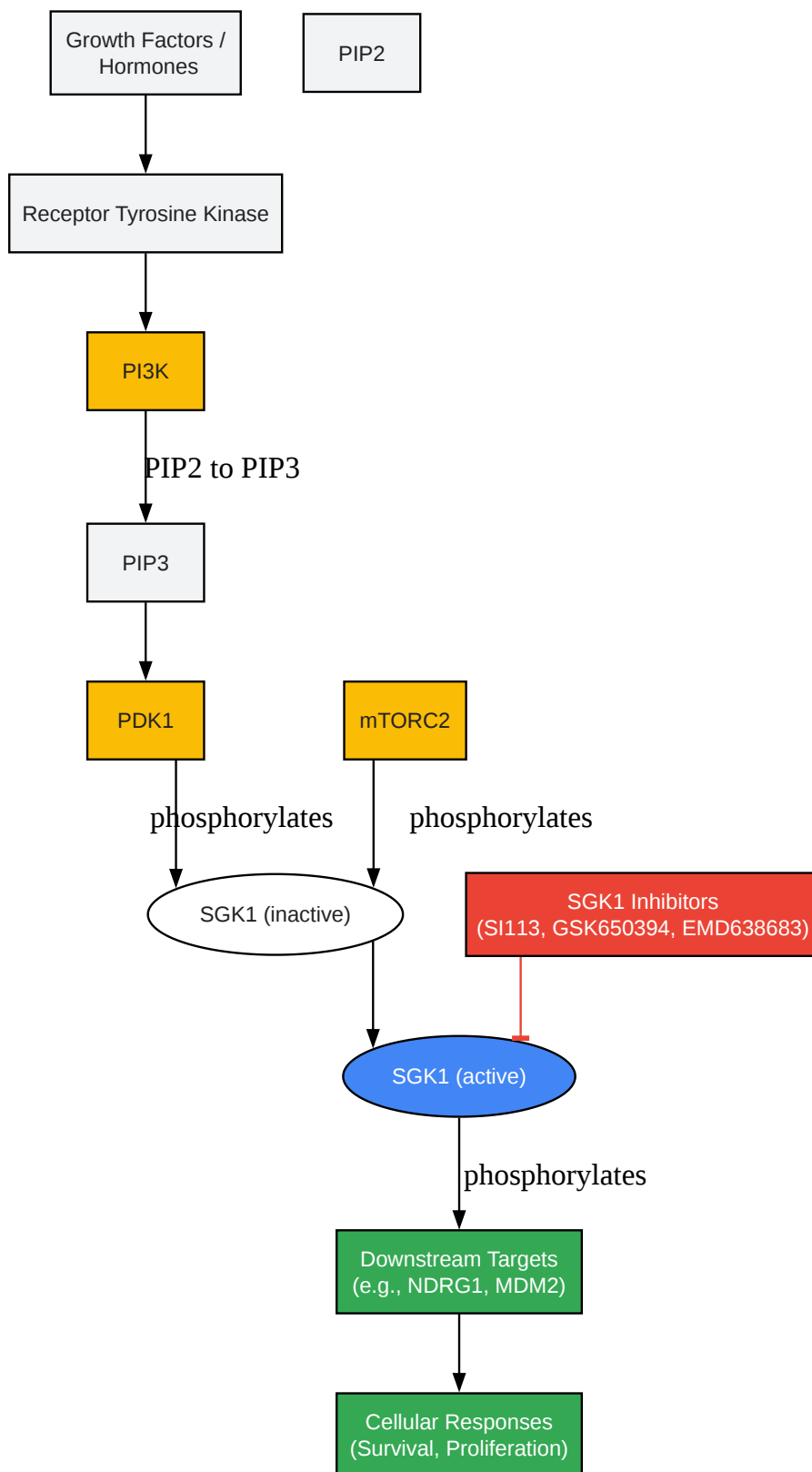

[Click to download full resolution via product page](#)

SGK1 signaling pathway and points of inhibition.

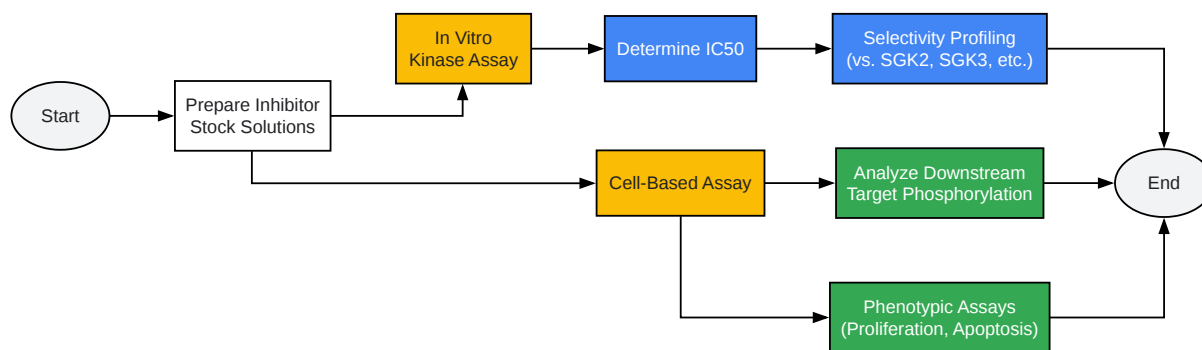

[Click to download full resolution via product page](#)

General experimental workflow for evaluating SGK1 inhibitors.

## Detailed Experimental Protocols

### In Vitro Kinase Assay for IC50 Determination of **SI113** (Immunoprecipitation-Based)

This protocol is based on the methodology used for characterizing pyrazolo[3,4-d]pyrimidine-based inhibitors like **SI113**.

#### 1. Cell Culture and Transfection:

- Culture a suitable cell line (e.g., HEK293T or RKO) in Dulbecco's Modified Eagle's Medium (DMEM) supplemented with 10% fetal bovine serum (FBS) and 1% penicillin-streptomycin.
- Transfect cells with a plasmid encoding Myc-tagged human SGK1 using a suitable transfection reagent.
- After 24-48 hours, lyse the cells in a lysis buffer (e.g., 50 mM Tris-HCl pH 7.5, 150 mM NaCl, 1% Triton X-100, 1 mM EDTA, 1 mM EGTA, supplemented with protease and phosphatase inhibitors).

#### 2. Immunoprecipitation of SGK1:

- Clarify the cell lysates by centrifugation.

- Incubate the supernatant with an anti-Myc antibody for 2-4 hours at 4°C with gentle rotation.
- Add Protein A/G agarose beads and incubate for another 1-2 hours.
- Wash the beads three to four times with lysis buffer and then with kinase assay buffer.

### 3. In Vitro Kinase Reaction:

- Resuspend the beads with immunoprecipitated Myc-SGK1 in a kinase assay buffer (e.g., 25 mM Tris-HCl pH 7.5, 5 mM  $\beta$ -glycerophosphate, 2 mM DTT, 0.1 mM  $\text{Na}_3\text{VO}_4$ , 10 mM  $\text{MgCl}_2$ ).
- Add a known concentration of a substrate peptide (e.g., Crosstide) and varying concentrations of the **SI113** inhibitor.
- Initiate the kinase reaction by adding ATP (e.g., 100  $\mu\text{M}$ ) and  $[\gamma\text{-}^{32}\text{P}]\text{ATP}$ .
- Incubate the reaction mixture at 30°C for a defined period (e.g., 20-30 minutes).

### 4. Measurement of Kinase Activity:

- Stop the reaction by adding a stop solution (e.g., 3% phosphoric acid).
- Spot a portion of the reaction mixture onto P81 phosphocellulose paper.
- Wash the paper extensively with phosphoric acid to remove unincorporated  $[\gamma\text{-}^{32}\text{P}]\text{ATP}$ .
- Measure the incorporated radioactivity using a scintillation counter.
- Calculate the percentage of inhibition for each inhibitor concentration and determine the  $\text{IC}_{50}$  value using non-linear regression analysis.

## Scintillation Proximity Assay (SPA) for $\text{IC}_{50}$ Determination of GSK650394

This protocol is a detailed method for determining the in vitro potency of SGK inhibitors.

### 1. Reagents and Materials:

- Recombinant active SGK1 and SGK2.
- PDK1 for SGK activation.
- Kinase buffer: 50 mM Tris (pH 7.5), 0.1 mM EGTA, 0.1 mM EDTA, 10 mM MgCl<sub>2</sub>, 0.1% β-mercaptoethanol, 1 mg/mL BSA.
- Biotinylated substrate peptide (e.g., CROSStide).
- [<sup>33</sup>P]ATP.
- Streptavidin-coated SPA beads.
- GSK650394 stock solution in DMSO.

#### 2. Kinase Activation:

- Activate SGK1 or SGK2 by incubating with PDK1 in the kinase buffer containing ATP for 30 minutes at 30°C.

#### 3. Kinase Reaction:

- Prepare a reaction mixture containing the activated SGK enzyme, the biotinylated substrate peptide, and varying concentrations of GSK650394 in the kinase buffer.
- Initiate the reaction by adding [<sup>33</sup>P]ATP.
- Incubate the reaction plate at room temperature for a specified time (e.g., 60-90 minutes).

#### 4. Signal Detection:

- Terminate the reaction by adding a stop solution containing EDTA.
- Add a slurry of streptavidin-coated SPA beads to each well. The biotinylated and phosphorylated substrate binds to the beads.
- When the radiolabeled phosphate is in close proximity to the scintillant in the beads, it emits light.

- Measure the light signal using a scintillation counter (e.g., a TopCount NXT).

#### 5. Data Analysis:

- Calculate the percentage of inhibition for each concentration of GSK650394.
- Determine the IC<sub>50</sub> value by fitting the data to a dose-response curve using appropriate software (e.g., GraphPad Prism).

## NDRG1 Phosphorylation Assay for IC<sub>50</sub> Determination of EMD638683

This cell-based assay measures the ability of an inhibitor to block the phosphorylation of a known SGK1 substrate.

#### 1. Cell Culture and Treatment:

- Plate a suitable cell line, such as HeLa cells, in 96-well plates and allow them to adhere overnight.
- Serum-starve the cells for a few hours to reduce basal kinase activity.
- Pre-treat the cells with varying concentrations of EMD638683 for 1-2 hours.
- Stimulate the cells with a known SGK1 activator, such as insulin or serum, for a short period (e.g., 15-30 minutes) to induce SGK1 activity and subsequent NDRG1 phosphorylation.

#### 2. Cell Lysis and Protein Quantification:

- Wash the cells with ice-cold PBS and lyse them in a suitable lysis buffer containing protease and phosphatase inhibitors.
- Determine the protein concentration of each lysate using a standard protein assay (e.g., BCA assay).

#### 3. Western Blotting:

- Separate equal amounts of protein from each sample by SDS-PAGE.

- Transfer the proteins to a nitrocellulose or PVDF membrane.
- Block the membrane with a blocking buffer (e.g., 5% non-fat dry milk or BSA in TBST).
- Incubate the membrane with a primary antibody specific for phosphorylated NDRG1 (pNDRG1).
- Wash the membrane and incubate with a horseradish peroxidase (HRP)-conjugated secondary antibody.
- Detect the signal using an enhanced chemiluminescence (ECL) substrate and an imaging system.
- To normalize for protein loading, strip the membrane and re-probe with an antibody against total NDRG1 or a housekeeping protein like GAPDH or  $\beta$ -actin.

#### 4. Data Analysis:

- Quantify the band intensities for pNDRG1 and the loading control using densitometry software.
- Calculate the ratio of pNDRG1 to the loading control for each treatment condition.
- Determine the percentage of inhibition of NDRG1 phosphorylation for each concentration of EMD638683 relative to the stimulated control.
- Calculate the IC<sub>50</sub> value by plotting the percentage of inhibition against the inhibitor concentration and fitting the data to a sigmoidal dose-response curve.

## Conclusion

This guide provides a comparative overview of the SGK1 inhibitors **SI113**, GSK650394, and EMD638683. The choice of inhibitor will depend on the specific experimental needs, considering factors such as required potency, the importance of selectivity against other SGK isoforms and related kinases, and the suitability for in vitro versus cell-based assays. The provided experimental protocols offer a starting point for researchers to evaluate these inhibitors in their own experimental setups. As the field of SGK1 research continues to evolve,



a thorough understanding of the available tools is essential for advancing our knowledge of SGK1's role in health and disease.

### Need Custom Synthesis?

BenchChem offers custom synthesis for rare earth carbides and specific isotopic labeling.

Email: [info@benchchem.com](mailto:info@benchchem.com) or [Request Quote Online](#).

## References

- 1. medchemexpress.com [medchemexpress.com]
- 2. SGK1 in Cancer: Biomarker and Drug Target - PMC [pmc.ncbi.nlm.nih.gov]
- 3. caymanchem.com [caymanchem.com]
- 4. researchgate.net [researchgate.net]
- 5. medchemexpress.com [medchemexpress.com]
- To cite this document: BenchChem. [A Comparative Guide to SGK1 Inhibitors: SI113 vs. Alternatives]. BenchChem, [2025]. [Online PDF]. Available at: [https://www.benchchem.com/product/b610833#comparing-si113-to-other-sgk1-inhibitors]

---

### Disclaimer & Data Validity:

The information provided in this document is for Research Use Only (RUO) and is strictly not intended for diagnostic or therapeutic procedures. While BenchChem strives to provide accurate protocols, we make no warranties, express or implied, regarding the fitness of this product for every specific experimental setup.

**Technical Support:** The protocols provided are for reference purposes. Unsure if this reagent suits your experiment? [[Contact our Ph.D. Support Team for a compatibility check](#)]

**Need Industrial/Bulk Grade?** [Request Custom Synthesis Quote](#)

# BenchChem

Our mission is to be the trusted global source of essential and advanced chemicals, empowering scientists and researchers to drive progress in science and industry.

## Contact

Address: 3281 E Guasti Rd

Ontario, CA 91761, United States

Phone: (601) 213-4426

Email: [info@benchchem.com](mailto:info@benchchem.com)