

A Comparative Guide to Rhodamine B PEG2-NH2 for Advanced Research Applications

Author: BenchChem Technical Support Team. **Date:** December 2025

Compound of Interest

Compound Name: Rhodamine B PEG2-NH2

Cat. No.: B11931447

[Get Quote](#)

For researchers, scientists, and drug development professionals, the selection of a fluorescent probe is a critical decision that can significantly impact experimental outcomes. This guide provides a comprehensive review of **Rhodamine B PEG2-NH2**, a versatile fluorescent molecule, and objectively compares its performance with common alternatives in key applications. Supported by experimental data and detailed protocols, this guide aims to facilitate informed decisions in the rapidly evolving fields of fluorescence imaging, drug delivery, and targeted protein degradation.

Rhodamine B PEG2-NH2 is a derivative of the well-established rhodamine B dye, featuring a short polyethylene glycol (PEG) linker and a terminal amine group. This bifunctional structure allows for covalent conjugation to a wide range of biomolecules and nanoparticles while the PEG linker enhances solubility and reduces steric hindrance. Its bright fluorescence in the orange-red spectrum makes it a popular choice for a variety of biological applications.

Performance Comparison with Alternative Fluorophores

The selection of a fluorescent probe is often a trade-off between brightness, photostability, and other photophysical properties. Here, we compare Rhodamine B with two other widely used fluorophores, Fluorescein and Cy5.

Property	Fluorescein	Rhodamine B	Cy5
**Molar Extinction Coefficient (ϵ) at λ_{max} ($\text{M}^{-1}\text{cm}^{-1}$) **	~70,000	~106,000	~250,000
Fluorescence Quantum Yield (Φ_f)	~0.93	~0.31 (in water)	~0.20
Photobleaching Quantum Yield (Φ_b)	~3-5 x 10 ⁻⁵	~10 ⁻⁶ - 10 ⁻⁷	~5 x 10 ⁻⁶
Relative Photostability	Low	Moderate	High
Excitation Maximum (nm)	~494	~570	~650
Emission Maximum (nm)	~521	~595	~670

Note: The photophysical properties of fluorophores can be influenced by their local chemical environment, including solvent, pH, and conjugation to other molecules. The data for Rhodamine B is for the parent molecule and may vary for the PEGylated derivative.

Key Applications and Experimental Protocols

Rhodamine B PEG2-NH2 has demonstrated utility across a range of applications, from cellular imaging to the development of novel therapeutics.

Fluorescence Imaging

Rhodamine B derivatives are extensively used for labeling and visualizing cellular structures.^[1] Its moderate photostability makes it suitable for a range of imaging experiments, though for prolonged live-cell imaging, more photostable dyes like Cy5 may be preferable.

Experimental Protocol: General Cell Staining with Rhodamine B Conjugates

- Sample Preparation: Grow cells on coverslips or in imaging-compatible plates.
- Fixation: Fix cells with 4% paraformaldehyde in PBS for 15-20 minutes at room temperature.

- Permeabilization (for intracellular targets): If targeting intracellular structures, permeabilize the cells with 0.1-0.5% Triton X-100 in PBS for 10-15 minutes.
- Blocking: Block non-specific binding sites with a suitable blocking buffer (e.g., 1% BSA in PBS) for 30-60 minutes.
- Staining: Incubate the cells with the **Rhodamine B PEG2-NH2** conjugated probe (e.g., an antibody) at the desired concentration (typically in the low $\mu\text{g/mL}$ range) in blocking buffer for 1-2 hours at room temperature or overnight at 4°C.
- Washing: Wash the cells three times with PBS for 5 minutes each to remove unbound probe.
- Mounting and Imaging: Mount the coverslips onto microscope slides using an antifade mounting medium. Image the cells using a fluorescence microscope with appropriate filter sets for Rhodamine B (Excitation: ~540-560 nm; Emission: ~570-620 nm).

Drug Delivery and Nanoparticle Tracking

The covalent attachment of **Rhodamine B PEG2-NH2** to nanoparticles or drug delivery systems enables the tracking of their biodistribution and cellular uptake. Studies have shown that rhodamine-labeled nanoparticles can be effectively visualized in vivo to assess their accumulation in target tissues.

Experimental Workflow: In Vivo Imaging of Labeled Nanoparticles

Workflow for in vivo imaging of nanoparticles labeled with **Rhodamine B PEG2-NH2**.

PROTAC Development

Proteolysis-targeting chimeras (PROTACs) are an emerging class of drugs that induce the degradation of specific proteins. **Rhodamine B PEG2-NH2** can be incorporated as a fluorescent tag on a PROTAC molecule to facilitate studies of its cellular uptake, distribution, and engagement with its target protein.[2]

Logical Relationship: Fluorescent PROTAC Action

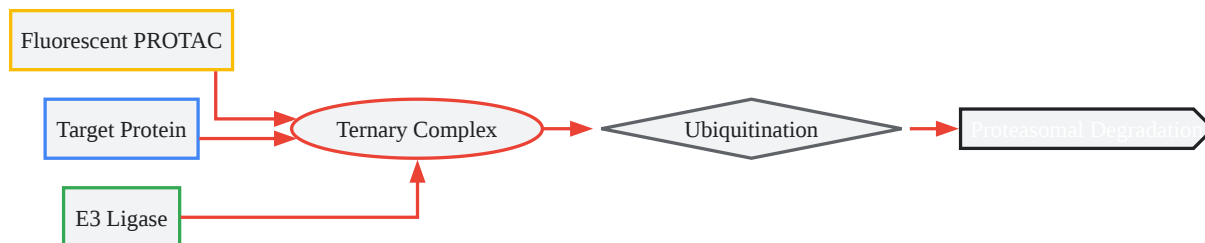

[Click to download full resolution via product page](#)

Visualizing the mechanism of a fluorescently labeled PROTAC.

Elucidating Signaling Pathways

Fluorescently labeled ligands or antibodies are invaluable tools for studying cellular signaling pathways. By tracking the localization and interaction of key signaling molecules, researchers can gain insights into the mechanisms that govern cellular processes. For example, a Rhodamine B-labeled probe can be used to visualize the epidermal growth factor receptor (EGFR) and its downstream signaling cascade.

Signaling Pathway: Simplified EGFR Signaling

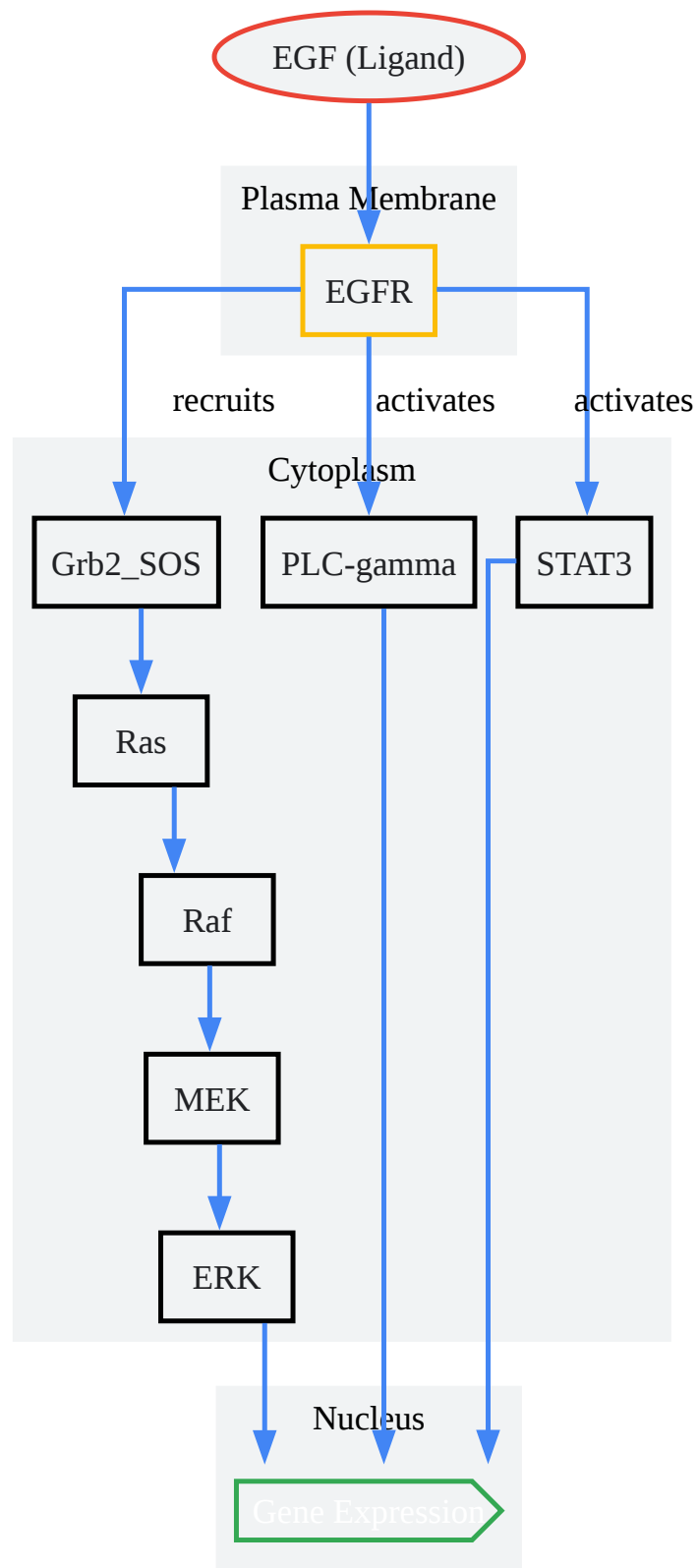

[Click to download full resolution via product page](#)

Simplified EGFR signaling pathway that can be studied using fluorescent probes.

Conclusion

Rhodamine B PEG2-NH2 is a valuable and versatile fluorescent probe for a wide range of research applications. Its bright fluorescence, moderate photostability, and functional handle for bioconjugation make it a reliable choice for fluorescence imaging, nanoparticle tracking, and the development of novel therapeutic modalities like PROTACs. While for applications requiring exceptional photostability, alternative dyes such as Cy5 may be more suitable, the overall balance of properties and cost-effectiveness of Rhodamine B derivatives ensures their continued prominence in the researcher's toolkit. Careful consideration of the specific experimental requirements and the comparative data presented in this guide will enable researchers to select the optimal fluorescent probe to achieve their scientific goals.

Need Custom Synthesis?

BenchChem offers custom synthesis for rare earth carbides and specific isotopic labeling.

Email: info@benchchem.com or [Request Quote Online](#).

References

- 1. A comprehensive pathway map of epidermal growth factor receptor signaling - PMC [pmc.ncbi.nlm.nih.gov]
- 2. fluorine-cómo2015.eu [fluorine-cómo2015.eu]
- To cite this document: BenchChem. [A Comparative Guide to Rhodamine B PEG2-NH2 for Advanced Research Applications]. BenchChem, [2025]. [Online PDF]. Available at: [https://www.benchchem.com/product/b11931447#literature-review-of-rhodamine-b-peg2-nh2-applications]

Disclaimer & Data Validity:

The information provided in this document is for Research Use Only (RUO) and is strictly not intended for diagnostic or therapeutic procedures. While BenchChem strives to provide accurate protocols, we make no warranties, express or implied, regarding the fitness of this product for every specific experimental setup.

Technical Support: The protocols provided are for reference purposes. Unsure if this reagent suits your experiment? [[Contact our Ph.D. Support Team for a compatibility check](#)]

Need Industrial/Bulk Grade? [Request Custom Synthesis Quote](#)

BenchChem

Our mission is to be the trusted global source of essential and advanced chemicals, empowering scientists and researchers to drive progress in science and industry.

Contact

Address: 3281 E Guasti Rd

Ontario, CA 91761, United States

Phone: (601) 213-4426

Email: info@benchchem.com