

A Comparative Guide to Phytosterol Quantification: An Inter-Laboratory Perspective

Author: BenchChem Technical Support Team. **Date:** December 2025

Compound of Interest

Compound Name: Δ^5 -Avenasterol-d4

Cat. No.: B1155743

[Get Quote](#)

For researchers, scientists, and professionals in drug development, the accurate quantification of phytosterols is paramount for quality control, efficacy assessment, and regulatory compliance. This guide provides an objective comparison of common methodologies for phytosterol analysis, supported by experimental data from various studies. While direct inter-laboratory proficiency testing data is often proprietary, this document synthesizes findings from single-laboratory validations and comparative studies to offer valuable insights into method performance.

Data Presentation: A Comparative Analysis of Analytical Methods

The quantification of phytosterols, including prevalent compounds such as campesterol, stigmasterol, and β -sitosterol, is predominantly accomplished through chromatographic techniques. Gas chromatography (GC) and liquid chromatography (LC) coupled with various detectors are the most common approaches. The following tables summarize the quantitative performance of different analytical methods as reported in the literature.

Table 1: Performance Characteristics of Gas Chromatography (GC) Methods for Phytosterol Quantification

Parameter	GC-FID	GC-MS
Linearity (R ²)	≥ 0.995[1]	0.9985[2]
Limit of Detection (LOD)	0.02 - 0.2 mg/kg[3]	0.36 mg/100 g[2]
Limit of Quantification (LOQ)	Not specified	1.20 mg/100 g[2]
Precision (RSD)	1.39% - 10.5%[1]	Repeatability <3%, Reproducibility <4%
Recovery	85.0% - 108%[1]	95.0% - 100.3%[2]

Table 2: Performance Characteristics of Liquid Chromatography (LC) and Other Methods

Parameter	HPLC-UV	LC-MS/MS	Colorimetric
Linearity (R ²)	Not specified	Not specified	Not specified
Limit of Detection (LOD)	Not specified	2 - 25 ng/mL[3]	0.162 ppm[4]
Limit of Quantification (LOQ)	Not specified	10 - 100 ng/mL[3]	0.541 ppm[4]
Precision (RSD)	Not specified	Not specified	1.23%[4]
Recovery	Not specified	82% - 91% (DES-DLLME)[3]	98.85% - 101.10%[4]

Experimental Protocols: A Step-by-Step Look at Phytosterol Analysis

The accurate quantification of phytosterols is highly dependent on the experimental protocol employed. The following sections detail the common methodologies for sample preparation, extraction, and analysis.

Sample Preparation and Extraction

A crucial first step in phytosterol analysis is the liberation of these compounds from the food or supplement matrix. Saponification is a widely used technique to hydrolyze sterol esters and glycosides, converting them into their free sterol forms.

Alkaline Saponification:

- A known quantity of the sample is weighed.
- An ethanolic potassium hydroxide (KOH) solution is added.
- The mixture is heated at a high temperature to facilitate saponification.[1]
- Following saponification, the unsaponifiable fraction containing the phytosterols is extracted using an organic solvent, such as toluene or hexane.[1][3]

Various extraction techniques can be employed to isolate the phytosterols from the saponified mixture, including:

- Liquid-Liquid Extraction (LLE): A straightforward method where the unsaponifiable matter is partitioned between the aqueous saponification mixture and an immiscible organic solvent.
- Solid-Phase Extraction (SPE): This technique allows for the purification and concentration of phytosterols from the extract.[5]
- Ultrasonic-Assisted Extraction (UAE): Utilizes high-frequency sound waves to disrupt cell walls and enhance the release of intracellular compounds.[6]
- Supercritical CO₂ Extraction: A green technology that uses supercritical carbon dioxide as the extraction solvent.[3]

Derivatization (for GC analysis)

For analysis by gas chromatography, phytosterols, which are non-volatile, must be derivatized to increase their volatility. The most common method is silylation.

- The extracted phytosterols are dried completely.

- A derivatizing agent, such as bis(trimethylsilyl)trifluoroacetamide (BSTFA), is added.
- The mixture is heated to convert the phytosterols into their trimethylsilyl (TMS) ethers.[1][3]

Analytical Instrumentation and Quantification

Gas Chromatography-Flame Ionization Detection (GC-FID):

- Principle: The derivatized sample is injected into the GC, where the phytosterols are separated based on their boiling points as they pass through a capillary column. The separated compounds are then detected by a flame ionization detector.
- Quantification: The concentration of each phytosterol is determined by comparing its peak area to that of an internal standard and a calibration curve prepared with certified reference standards.[1]

Gas Chromatography-Mass Spectrometry (GC-MS):

- Principle: Similar to GC-FID, but the separated compounds are detected by a mass spectrometer, which provides information about their mass-to-charge ratio, allowing for more specific identification.
- Quantification: Quantification is typically performed using selected ion monitoring (SIM) mode for enhanced sensitivity and selectivity.[5]

High-Performance Liquid Chromatography (HPLC):

- Principle: HPLC separates phytosterols in their native (non-derivatized) form based on their differential partitioning between a stationary phase (e.g., C18 column) and a mobile phase. [3] Detection is often achieved using a UV detector.
- Advantages: Eliminates the need for a derivatization step.

Liquid Chromatography-Tandem Mass Spectrometry (LC-MS/MS):

- Principle: This technique couples the separation power of LC with the high selectivity and sensitivity of tandem mass spectrometry, allowing for the direct analysis of phytosterols without derivatization.[3]

- Advantages: Offers high sensitivity and the ability to analyze complex matrices with minimal sample cleanup.

Visualizing the Workflow and Comparison

To better illustrate the processes involved in phytosterol quantification and the basis of comparison, the following diagrams are provided.

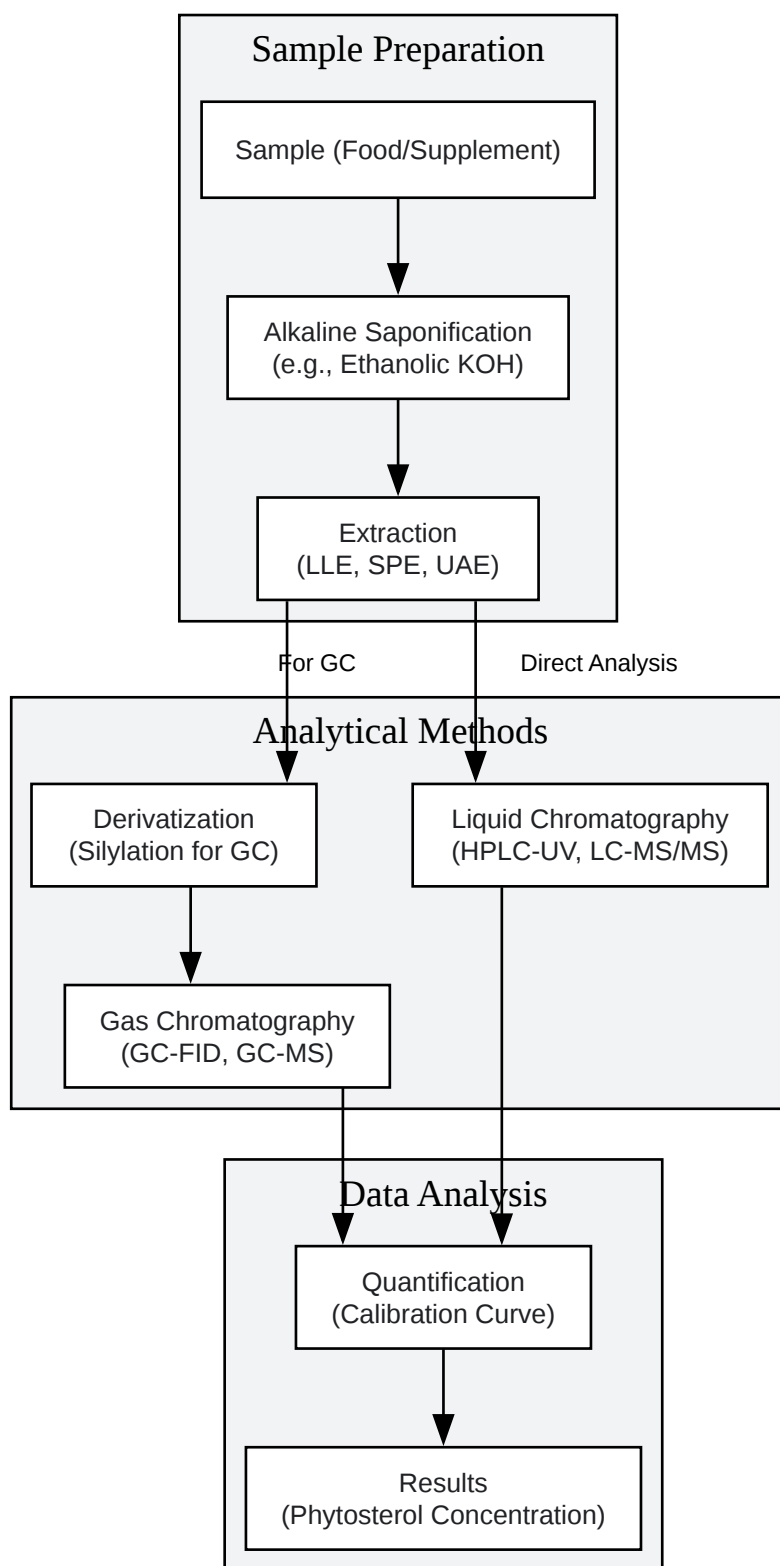

[Click to download full resolution via product page](#)

Caption: Generalized experimental workflow for phytosterol quantification.

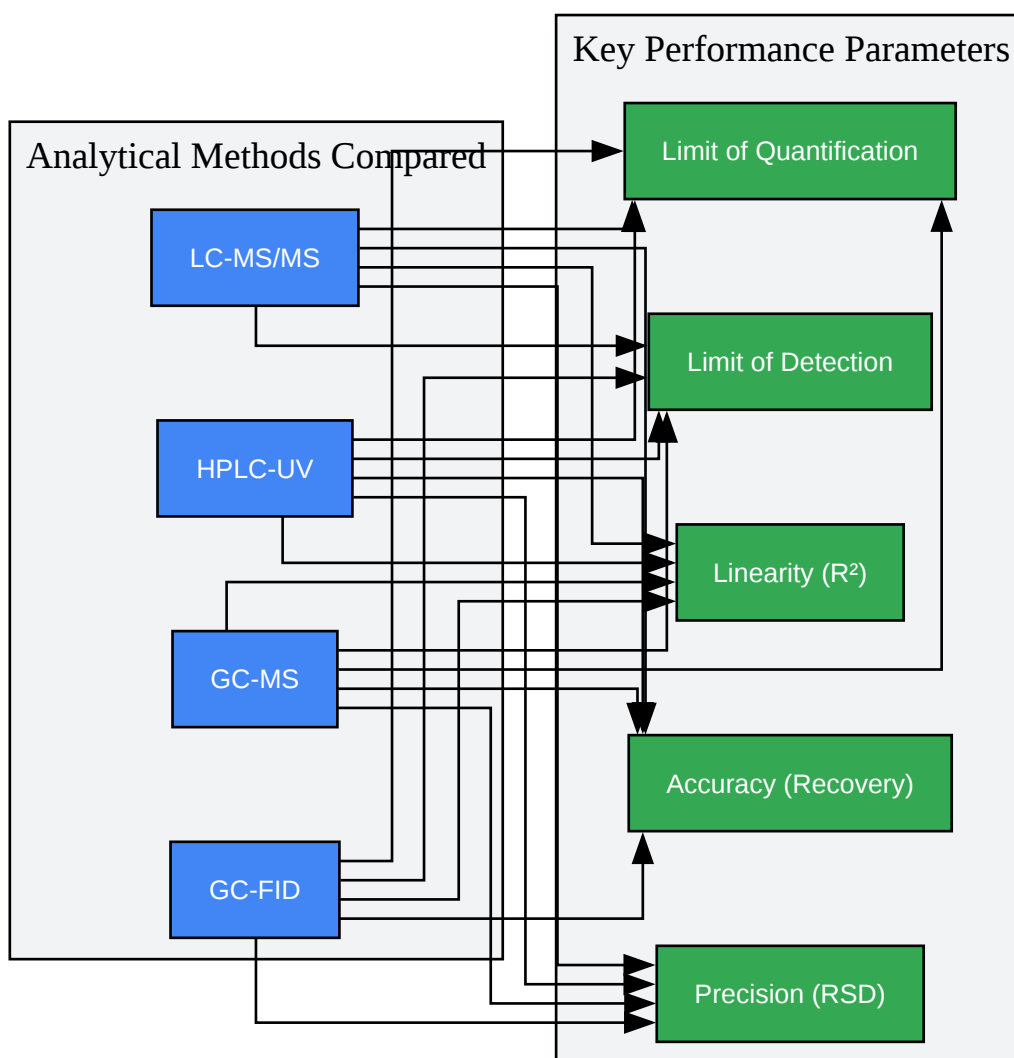

[Click to download full resolution via product page](#)

Caption: Logical relationship for the comparison of phytosterol quantification methods.

Need Custom Synthesis?

BenchChem offers custom synthesis for rare earth carbides and specific isotopic labeling.

Email: info@benchchem.com or [Request Quote Online](#).

References

- 1. aocs.org [aocs.org]

- 2. Phytosterols: Extraction Methods, Analytical Techniques, and Biological Activity - PubMed [pubmed.ncbi.nlm.nih.gov]
- 3. researchgate.net [researchgate.net]
- 4. researchgate.net [researchgate.net]
- 5. aocs.org [aocs.org]
- 6. mdpi.com [mdpi.com]
- To cite this document: BenchChem. [A Comparative Guide to Phytosterol Quantification: An Inter-Laboratory Perspective]. BenchChem, [2025]. [Online PDF]. Available at: [https://www.benchchem.com/product/b1155743#inter-laboratory-comparison-of-phytosterol-quantification-methods]

Disclaimer & Data Validity:

The information provided in this document is for Research Use Only (RUO) and is strictly not intended for diagnostic or therapeutic procedures. While BenchChem strives to provide accurate protocols, we make no warranties, express or implied, regarding the fitness of this product for every specific experimental setup.

Technical Support: The protocols provided are for reference purposes. Unsure if this reagent suits your experiment? [[Contact our Ph.D. Support Team for a compatibility check](#)]

Need Industrial/Bulk Grade? [Request Custom Synthesis Quote](#)

BenchChem

Our mission is to be the trusted global source of essential and advanced chemicals, empowering scientists and researchers to drive progress in science and industry.

Contact

Address: 3281 E Guasti Rd

Ontario, CA 91761, United States

Phone: (601) 213-4426

Email: info@benchchem.com