

A Comparative Guide to PSI-7409 Tetrasodium and Other Nucleotide Analog Inhibitors

Author: BenchChem Technical Support Team. **Date:** December 2025

Compound of Interest

Compound Name: *PSI-7409 tetrasodium*

Cat. No.: *B15567950*

[Get Quote](#)

For researchers, scientists, and drug development professionals, understanding the nuanced differences between nucleotide analog inhibitors is critical for advancing antiviral therapies. This guide provides an objective comparison of **PSI-7409 tetrasodium**, the active triphosphate metabolite of sofosbuvir, with other prominent nucleotide analog inhibitors: remdesivir, favipiravir, and tenofovir disoproxil fumarate (TDF).

Mechanism of Action: A Tale of Two Strategies

Nucleotide analog inhibitors function as "Trojan horses," mimicking natural nucleosides to deceive viral polymerases, the enzymes responsible for replicating the viral genome. Once incorporated into the growing viral RNA or DNA chain, they disrupt the replication process. However, the precise method of disruption varies.

PSI-7409 tetrasodium, the active form of sofosbuvir, acts as a chain terminator. After intracellular conversion to PSI-7409, it is incorporated into the nascent hepatitis C virus (HCV) RNA chain by the NS5B polymerase. Its modified structure prevents the addition of subsequent nucleotides, thereby halting viral replication.

Remdesivir, another adenosine analog prodrug, also functions primarily as a chain terminator against a broad range of RNA viruses, including SARS-CoV-2. Its active triphosphate form is incorporated into the viral RNA, causing a delayed chain termination.

Favipiravir presents a dual mechanism of action. As a purine analog, its active form, favipiravir-RTP, can be incorporated into viral RNA, where it can act as a chain terminator. Additionally, it

is proposed to induce "lethal mutagenesis," causing an accumulation of errors in the viral genome that renders the progeny viruses non-viable.[1][2]

Tenofovir disoproxil fumarate (TDF) is a prodrug of tenofovir, an adenosine monophosphate analog. Its active diphosphate form is a potent inhibitor of the reverse transcriptase of human immunodeficiency virus (HIV) and the polymerase of hepatitis B virus (HBV).[3] Upon incorporation into the growing viral DNA chain, it causes chain termination.

Comparative Efficacy and Cytotoxicity

The potency and safety of these inhibitors are paramount. The following tables summarize their in vitro antiviral activity (EC50) and cytotoxicity (CC50) against their respective target viruses and in various cell lines. The selectivity index (SI), the ratio of CC50 to EC50, provides a measure of the therapeutic window.

Inhibitor	Virus	Cell Line	EC50 (μM)	Reference
PSI-7409 (active form of Sofosbuvir)	HCV Genotype 1b	-	1.6	[4]
HCV Genotype 2a	-	2.8	[4]	
HCV Genotype 3a	-	0.7		
HCV Genotype 4a	-	2.6		
Remdesivir	SARS-CoV-2	Vero E6	0.46	
Favipiravir	Influenza A (H1N1)	MDCK	0.15 - 0.47	
Tenofovir	HIV-1	Lymphoblastoid cells	0.04 - 8.5	

Table 1: Comparative Antiviral Activity (EC50)

Inhibitor	Cell Line	CC50 (μM)	Reference
PSI-7409 (active form of Sofosbuvir)	Human DNA Polymerase α	550	
Human DNA Polymerase β and γ	>1000		
Remdesivir	MT-4	1.7 - >20	
Tenofovir	HepG2 (Liver)	398	
Skeletal Muscle Cells	870		
Erythroid Progenitor Cells	>200		

Table 2: Comparative Cytotoxicity (CC50)

Resistance Profiles

The emergence of drug resistance is a significant challenge in antiviral therapy. Resistance typically arises from mutations in the viral polymerase that reduce the inhibitor's binding affinity or incorporation efficiency.

Inhibitor	Virus	Key Resistance Mutation(s)	Effect on Susceptibility	Reference
Sofosbuvir	HCV	S282T in NS5B	2.4 to 19.4-fold reduction	
Remdesivir	SARS-CoV-2	V166L, E802D in nsp12	1.5 to 2.5-fold increase in EC50	
Favipiravir	Influenza A	K229R in PB1 and P653L in PA	Two mutations required for robust resistance	
Tenofovir	HIV-1	K65R in Reverse Transcriptase	Increased resistance	

Table 3: Key Resistance Mutations

Pharmacokinetics

The clinical utility of these prodrugs is heavily dependent on their pharmacokinetic properties, which determine their absorption, distribution, metabolism, and excretion.

Inhibitor (Prodrug)	Active Metabolite	Plasma Half-life (Prodrug)	Plasma Half-life (Active/Main Metabolite)	Primary Route of Elimination	Reference
Sofosbuvir	PSI-7409 (GS-461203)	~0.4 hours	~27 hours (GS-331007 - inactive)	Renal (as GS-331007)	
Remdesivir	GS-443902	~0.48 hours	~26.6 hours (GS-441524 - nucleoside)	Renal	
Favipiravir	Favipiravir-RTP	Variable (dose-dependent)	Not well-defined in plasma	Metabolism, then renal	
Tenofovir Disoproxil Fumarate	Tenofovir Diphosphate	-	~17 hours (Tenofovir)	Renal	

Table 4: Comparative Pharmacokinetic Parameters

Experimental Protocols

Antiviral Activity Assay (Plaque Reduction Assay)

Objective: To determine the concentration of an antiviral compound that inhibits the formation of viral plaques by 50% (EC50).

Methodology:

- **Cell Seeding:** Plate a suitable host cell line (e.g., Vero E6 for SARS-CoV-2, MDCK for influenza) in 6- or 12-well plates and grow to confluency.
- **Compound Preparation:** Prepare a stock solution of the test compound in an appropriate solvent and make serial dilutions to achieve a range of concentrations.
- **Virus Infection:** Infect the confluent cell monolayers with a known titer of the virus for 1 hour at 37°C to allow for viral adsorption.
- **Compound Addition:** Remove the virus inoculum and add an overlay medium containing the different concentrations of the test compound. Include a virus control (no compound) and a cell control (no virus, no compound).
- **Incubation:** Incubate the plates at 37°C in a CO₂ incubator for a period sufficient for plaque formation (typically 2-3 days).
- **Plaque Visualization:** Fix the cells (e.g., with 10% formaldehyde) and stain with a solution like crystal violet to visualize the plaques.
- **Data Analysis:** Count the number of plaques in each well and calculate the EC₅₀ value as the concentration of the compound that reduces the plaque number by 50% compared to the virus control.

Cytotoxicity Assay (MTT Assay)

Objective: To determine the concentration of a compound that reduces cell viability by 50% (CC₅₀).

Methodology:

- **Cell Seeding:** Seed cells in a 96-well plate at a predetermined density and allow them to adhere overnight.
- **Compound Treatment:** Add serial dilutions of the test compound to the wells. Include untreated cells as a control.
- **Incubation:** Incubate the plate for a duration that corresponds to the antiviral assay (e.g., 48-72 hours).

- **MTT Addition:** Add MTT (3-(4,5-dimethylthiazol-2-yl)-2,5-diphenyltetrazolium bromide) solution to each well and incubate for 2-4 hours. Metabolically active cells will reduce the yellow MTT to purple formazan crystals.
- **Solubilization:** Add a solubilizing agent (e.g., DMSO) to dissolve the formazan crystals.
- **Absorbance Measurement:** Measure the absorbance of the solution at 570 nm using a microplate reader.
- **Data Analysis:** Calculate cell viability as a percentage of the untreated control and determine the CC50 value.

Visualizing the Pathways

Metabolic Activation Pathways

The following diagrams illustrate the intracellular conversion of these prodrugs into their active triphosphate forms.

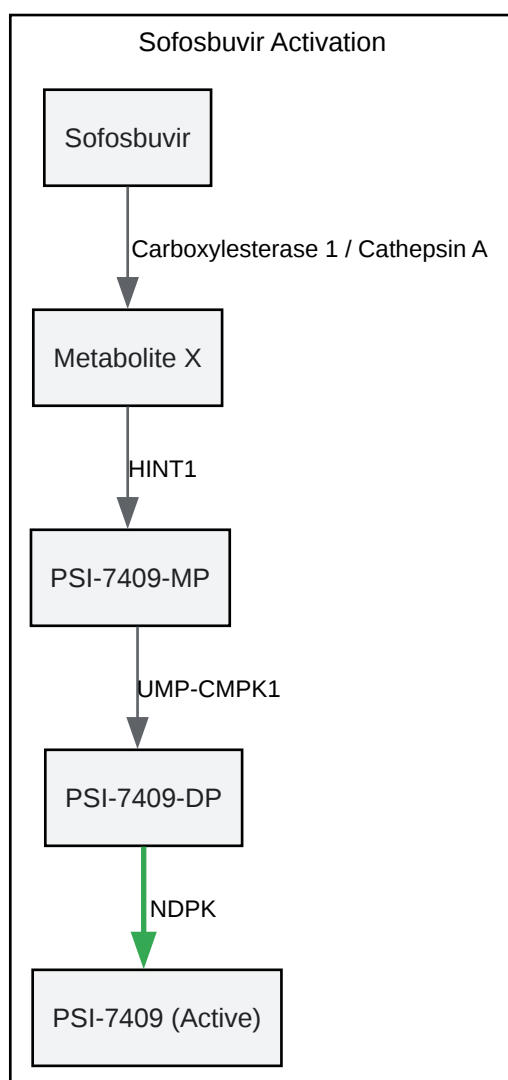

[Click to download full resolution via product page](#)

Metabolic activation of Sofosbuvir.

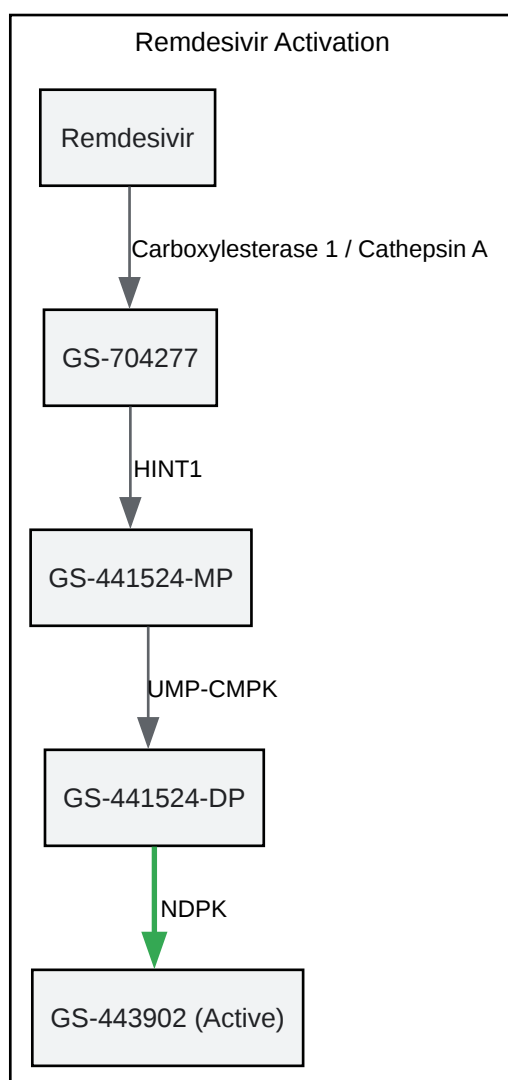

[Click to download full resolution via product page](#)

Metabolic activation of Remdesivir.

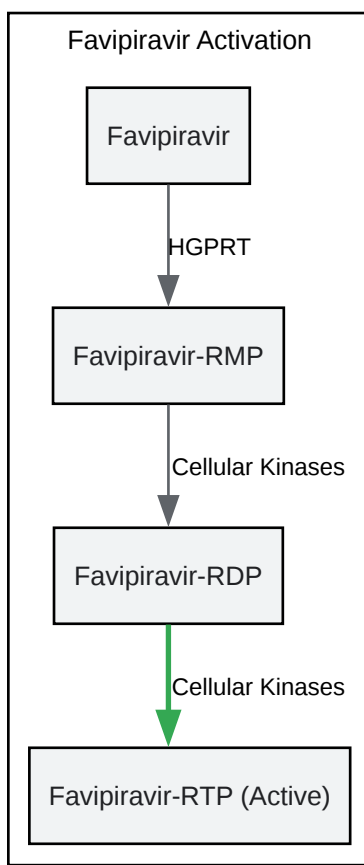

[Click to download full resolution via product page](#)

Metabolic activation of Favipiravir.

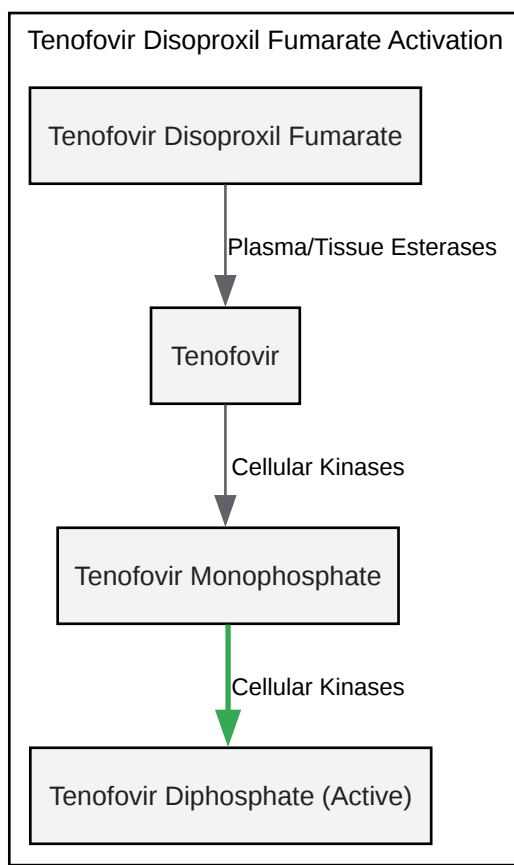

[Click to download full resolution via product page](#)

Metabolic activation of TDF.

Experimental Workflow: In Vitro Resistance Selection

The following diagram outlines a typical workflow for selecting and characterizing drug-resistant viral variants in a laboratory setting.

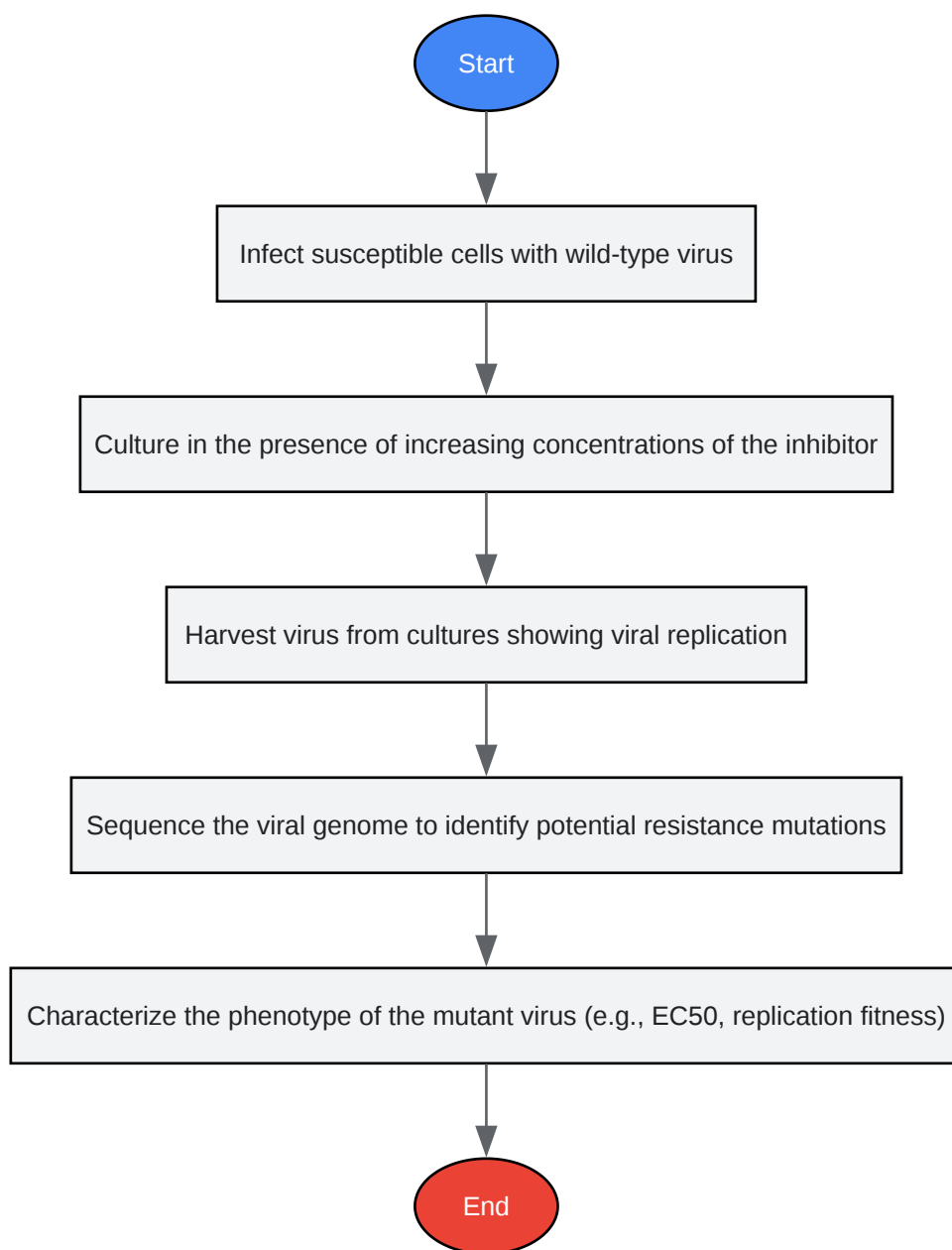

[Click to download full resolution via product page](#)

Workflow for in vitro resistance selection.

Need Custom Synthesis?

BenchChem offers custom synthesis for rare earth carbides and specific isotopic labeling.

Email: info@benchchem.com or [Request Quote Online](#).

References

- 1. benchchem.com [benchchem.com]
- 2. researchgate.net [researchgate.net]
- 3. go.drugbank.com [go.drugbank.com]
- 4. Screening for Antiviral Activity: MTT Assay | Springer Nature Experiments [experiments.springernature.com]
- To cite this document: BenchChem. [A Comparative Guide to PSI-7409 Tetrasodium and Other Nucleotide Analog Inhibitors]. BenchChem, [2025]. [Online PDF]. Available at: [https://www.benchchem.com/product/b15567950#psi-7409-tetrasodium-vs-other-nucleotide-analog-inhibitors]

Disclaimer & Data Validity:

The information provided in this document is for Research Use Only (RUO) and is strictly not intended for diagnostic or therapeutic procedures. While BenchChem strives to provide accurate protocols, we make no warranties, express or implied, regarding the fitness of this product for every specific experimental setup.

Technical Support: The protocols provided are for reference purposes. Unsure if this reagent suits your experiment? [[Contact our Ph.D. Support Team for a compatibility check](#)]

Need Industrial/Bulk Grade? [Request Custom Synthesis Quote](#)

BenchChem

Our mission is to be the trusted global source of essential and advanced chemicals, empowering scientists and researchers to drive progress in science and industry.

Contact

Address: 3281 E Guasti Rd

Ontario, CA 91761, United States

Phone: (601) 213-4426

Email: info@benchchem.com