

# A Comparative Guide to Gadusol and Oxybenzone: Efficacy, Safety, and Mechanisms

**Author:** BenchChem Technical Support Team. **Date:** December 2025

## Compound of Interest

Compound Name: *Gadusol*

Cat. No.: *B1210850*

[Get Quote](#)

For Researchers, Scientists, and Drug Development Professionals

The increasing demand for effective and safe sun protection has spurred research into novel sunscreen agents. This guide provides a detailed, evidence-based comparison of the natural compound **gadusol** and the widely used synthetic agent oxybenzone (benzophenone-3). We will delve into their efficacy as ultraviolet (UV) filters, their underlying mechanisms of action, and their respective safety profiles, supported by experimental data.

## Efficacy as UV Filters

The primary function of a sunscreen agent is to absorb or block harmful UV radiation. The efficacy of **gadusol** and oxybenzone in this regard can be evaluated by their UV absorption spectra, photostability, and in vitro/in vivo protection factors.

## UV Absorption

**Gadusol** exhibits a strong absorption in the UVB and UVC regions, with its absorption maximum being pH-dependent. In its enol form (acidic pH), it absorbs maximally at approximately 268 nm, while the enolate form (neutral pH) shows a red-shifted maximum at around 296 nm.<sup>[1]</sup> Oxybenzone has a broader spectrum of absorption, covering both UVB and UVA regions.

Table 1: UV Absorption Properties of **Gadusol** and Oxybenzone

Property	Gadusol	Oxybenzone
UVB Absorption	Strong	Strong
UVA Absorption	Weak	Moderate
Maximum Absorption ( $\lambda_{max}$ )	~296 nm (at neutral pH)[1]	Broad absorption in UVA and UVB
Molar Absorptivity ( $\epsilon$ )	21,800 L mol <sup>-1</sup> cm <sup>-1</sup> (at 296 nm)[1]	Data varies with solvent

## Photostability

Photostability, the ability of a molecule to remain stable upon exposure to UV radiation, is a critical parameter for sunscreen efficacy. Theoretical studies suggest that both the enol and enolate forms of **gadusol** undergo rapid deactivation, efficiently dissipating light energy as heat, which contributes to its high photostability.[2] The photodecomposition quantum yield for the enolate form of **gadusol** (**gadusolate**), which is the predominant form at physiological pH, is remarkably low at approximately  $1.4 \times 10^{-4}$ , indicating high photostability.[3] While oxybenzone is also a potent UV absorber, some studies suggest it can be less photostable and can generate reactive oxygen species upon irradiation.[4]

Table 2: Photostability of **Gadusol** and Oxybenzone

Compound	Photodecomposition Quantum Yield ( $\Phi$ )	Experimental Conditions
Gadusolate (Gadusol at neutral pH)	$1.4 \times 10^{-4}$ [3]	Aqueous solution
Oxybenzone	Varies depending on the medium and presence of photosensitizers[5]	Aqueous solution, aerosols

## Safety Profile

The safety of sunscreen agents is of paramount importance, encompassing both human health and environmental impact.

## Human Health

- **Gadusol**: Studies have shown that **gadusol** is less toxic than oxybenzone in cellular toxicity assays using Vero E6 fibroblasts. Furthermore, it was found to be non-mutagenic in the Ames test and non-toxic in the comet assay.[6] In vivo studies in zebrafish embryos suggest that **gadusol** does not function as an antioxidant but rather as a primary sunscreen by absorbing UVB and preventing DNA damage, specifically the formation of cyclobutane pyrimidine dimers (CPDs).[7][8]
- **Oxybenzone**: A significant body of evidence has raised concerns about the safety of oxybenzone. It has been shown to be a potential endocrine disruptor, acting as an estrogen receptor agonist and an androgen receptor antagonist in vitro.[9][10] Perinatal exposure in mice has been linked to altered mammary gland morphology.[11]

## Environmental Impact

- **Gadusol**: As a naturally occurring compound in many marine organisms, it is hypothesized that **gadusol** would not cause negative environmental effects.[6]
- **Oxybenzone**: Oxybenzone has been identified as a significant environmental contaminant, particularly detrimental to coral reefs.[12] Under UV light, corals metabolize oxybenzone into a potent phototoxin, leading to coral bleaching and death.[13] This has led to bans on oxybenzone-containing sunscreens in several regions to protect marine ecosystems.

## Mechanisms of Action

### Photoprotective Mechanism of Gadusol

**Gadusol**'s primary photoprotective mechanism involves the direct absorption of UVB radiation, thereby preventing it from reaching and damaging cellular components like DNA. This is supported by studies in zebrafish embryos where the absence of **gadusol** leads to increased formation of UVB-induced cyclobutane pyrimidine dimers (CPDs) and subsequent apoptosis.[7][8]

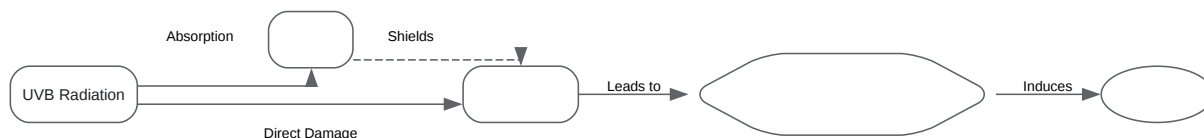

[Click to download full resolution via product page](#)

**Gadusol's photoprotective mechanism.**

## Oxybenzone's Adverse Effects

Oxybenzone can interfere with the endocrine system by binding to hormone receptors. In vitro studies have demonstrated its ability to act as an agonist for the estrogen receptor and an antagonist for the androgen receptor.[9][10] This interaction can disrupt normal hormonal signaling pathways.

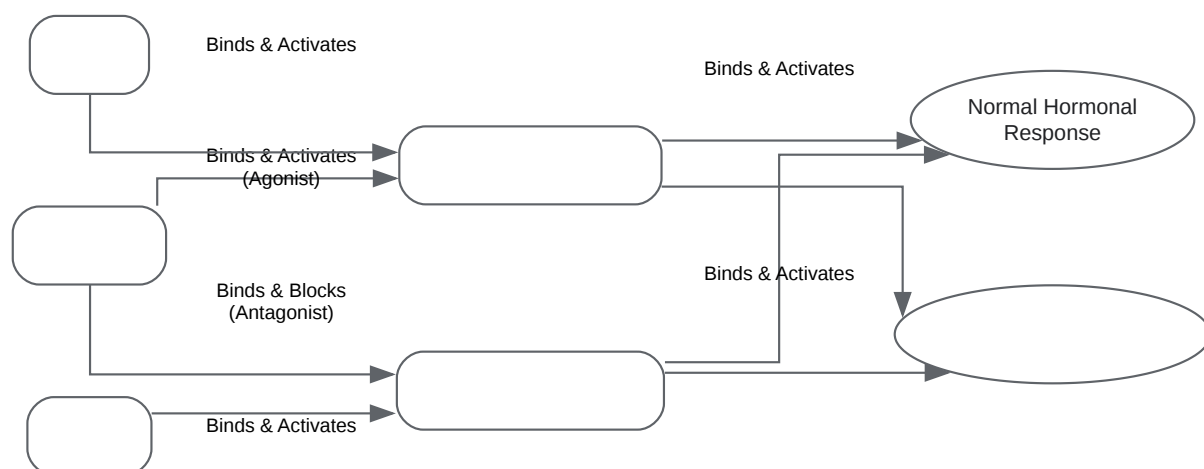

[Click to download full resolution via product page](#)

**Oxybenzone's endocrine disruption pathway.**

In corals, oxybenzone is metabolized into phototoxic glucoside conjugates. Upon exposure to UV light, these conjugates generate reactive oxygen species (ROS) that damage the coral's symbiotic algae (zooxanthellae), leading to their expulsion, a phenomenon known as coral bleaching.[12][13]

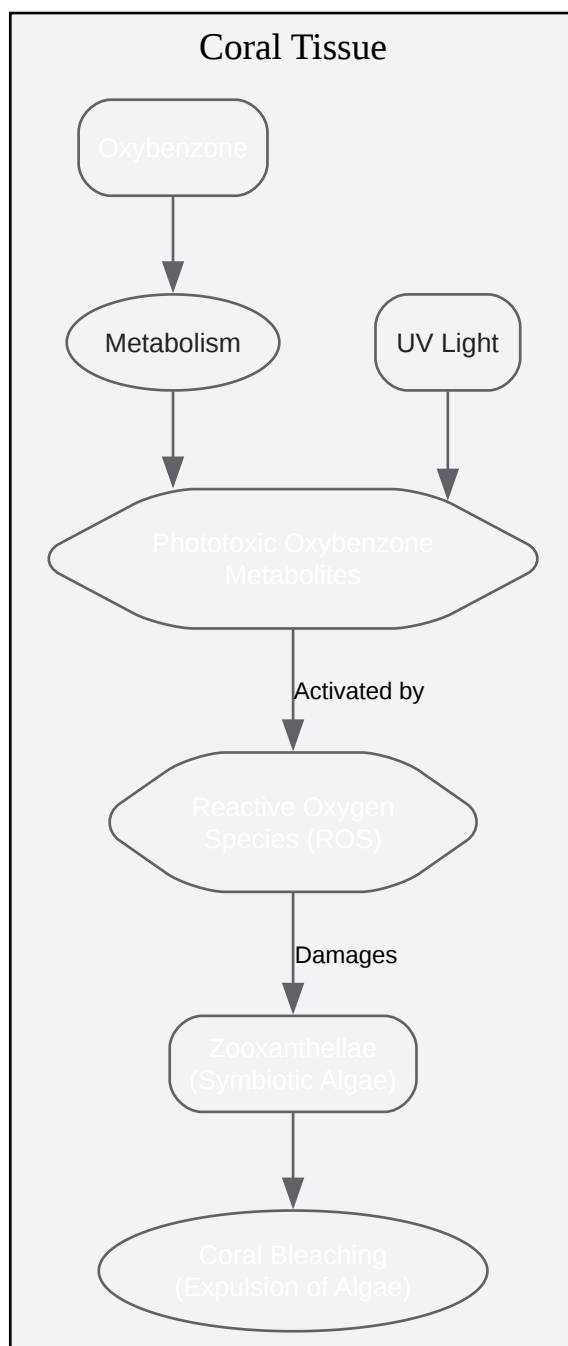

[Click to download full resolution via product page](#)

Oxybenzone-induced coral bleaching pathway.

## Experimental Protocols

### In Vitro SPF Measurement

The in vitro Sun Protection Factor (SPF) can be determined using spectrophotometric analysis of a thin film of the sunscreen product applied to a substrate like polymethylmethacrylate (PMMA) plates.

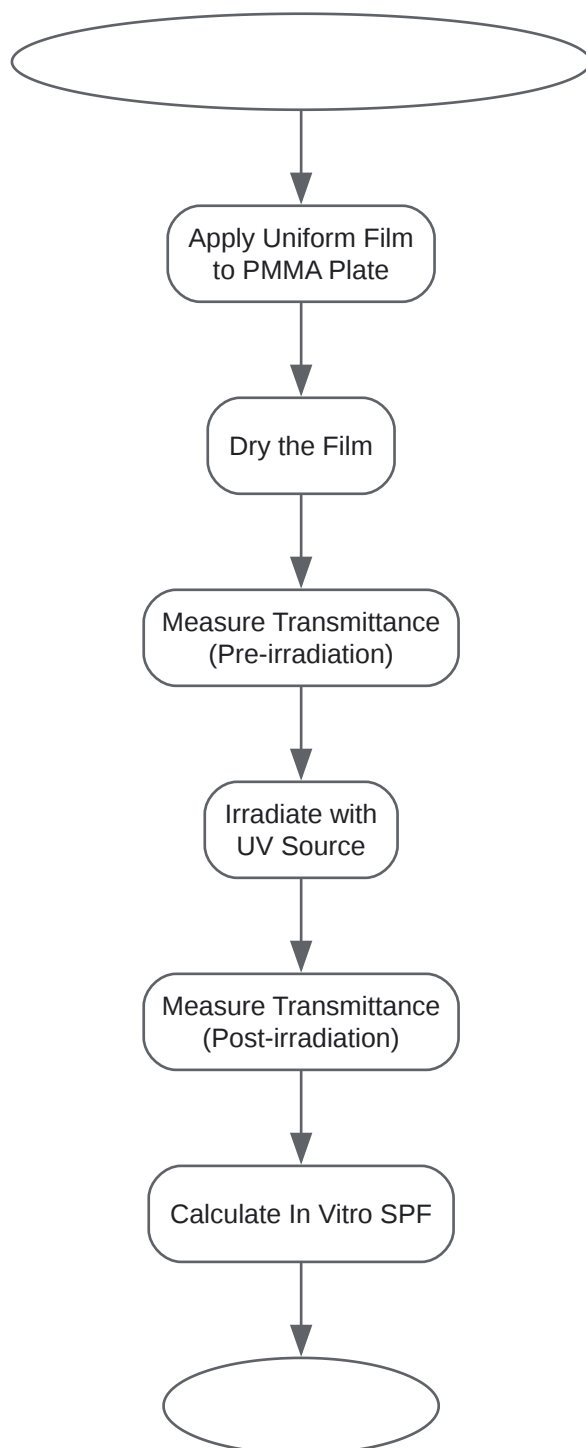

[Click to download full resolution via product page](#)

### Workflow for in vitro SPF determination.

#### Protocol:

- **Sample Preparation:** Prepare a formulation containing a known concentration of the test compound (**gadusol** or oxybenzone).
- **Application:** Apply a precise and uniform layer of the formulation onto a roughened PMMA plate.
- **Drying:** Allow the film to dry completely in a dark, controlled environment.
- **Pre-irradiation Measurement:** Measure the transmittance of UV radiation through the plate at various wavelengths using a spectrophotometer.
- **Irradiation:** Expose the plate to a controlled dose of UV radiation from a solar simulator.
- **Post-irradiation Measurement:** Re-measure the transmittance of UV radiation.
- **Calculation:** Calculate the in vitro SPF using a standardized equation that integrates the transmittance data with the erythemal action spectrum.

## Photostability Assessment using HPLC

High-Performance Liquid Chromatography (HPLC) is a robust method for quantifying the degradation of a sunscreen agent after UV exposure.

#### Protocol:

- **Sample Preparation:** Prepare solutions of **gadusol** and oxybenzone in a suitable solvent (e.g., methanol).
- **Initial Analysis:** Analyze the initial concentration of the compounds using a validated HPLC method with a photodiode array (PDA) detector.
- **UV Irradiation:** Expose the solutions to a controlled source of UV radiation for specific time intervals.

- **Post-irradiation Analysis:** At each time point, analyze the concentration of the remaining parent compound and any potential photodegradation products by HPLC.
- **Data Analysis:** Plot the concentration of the sunscreen agent as a function of irradiation time to determine the degradation kinetics and calculate the photodecomposition quantum yield.

## Zebrafish Embryotoxicity Assay

The zebrafish embryo model is a valuable tool for assessing the developmental toxicity of compounds.

Protocol:

- **Embryo Collection:** Collect freshly fertilized zebrafish embryos.
- **Exposure:** Place the embryos in multi-well plates containing a range of concentrations of the test compound (**gadusol** or oxybenzone) or a control solution.
- **Incubation:** Incubate the embryos at a controlled temperature (e.g., 28.5°C).
- **Endpoint Assessment:** At specific time points (e.g., 24, 48, 72 hours post-fertilization), assess various endpoints, including mortality, hatching rate, heart rate, and morphological abnormalities, under a microscope.
- **Data Analysis:** Determine the concentration at which adverse effects are observed and calculate metrics such as the LC50 (lethal concentration for 50% of the population).

## Conclusion

**Gadusol** presents a promising natural alternative to synthetic sunscreen agents like oxybenzone. It demonstrates high photostability and a favorable safety profile, effectively protecting against UVB-induced DNA damage without the endocrine-disrupting and ecotoxicological concerns associated with oxybenzone. While oxybenzone offers broader UV protection, its potential adverse effects on human health and the environment warrant careful consideration. Further research, including direct comparative in vivo SPF studies and long-term safety assessments in humans, is necessary to fully elucidate the potential of **gadusol** as a next-generation sunscreen ingredient. The development of sustainable and biocompatible



photoprotective agents is a critical area of research for both the pharmaceutical and cosmetic industries.

### Need Custom Synthesis?

BenchChem offers custom synthesis for rare earth carbides and specific isotopic labeling.

Email: [info@benchchem.com](mailto:info@benchchem.com) or [Request Quote Online](#).

## References

- 1. researchgate.net [researchgate.net]
- 2. Computational Exploration of the Photoprotective Potential of Gadusol - PMC [pmc.ncbi.nlm.nih.gov]
- 3. lcms.cz [lcms.cz]
- 4. researchgate.net [researchgate.net]
- 5. Photoinitiated Degradation Kinetics of the Organic UV Filter Oxybenzone in Solutions and Aerosols: Impacts of Salt, Photosensitizers, and the Medium - PMC [pmc.ncbi.nlm.nih.gov]
- 6. patents.justia.com [patents.justia.com]
- 7. Gadusol is a maternally provided sunscreen that protects fish embryos from DNA damage - PMC [pmc.ncbi.nlm.nih.gov]
- 8. Gadusol is a maternally provided sunscreen that protects fish embryos from DNA damage - PMC [pmc.ncbi.nlm.nih.gov]
- 9. researchgate.net [researchgate.net]
- 10. Oestrogenic and androgenic activity of oxybenzone and methylparaben in vitro - PMC [pmc.ncbi.nlm.nih.gov]
- 11. Exposure to low doses of oxybenzone during perinatal development alters mammary gland morphology in male and female mice - PubMed [pubmed.ncbi.nlm.nih.gov]
- 12. sciencepolicyjournal.org [sciencepolicyjournal.org]
- 13. Sunscreen's coral-killing mechanism uncovered | Research | Chemistry World [chemistryworld.com]
- To cite this document: BenchChem. [A Comparative Guide to Gadusol and Oxybenzone: Efficacy, Safety, and Mechanisms]. BenchChem, [2025]. [Online PDF]. Available at:

[<https://www.benchchem.com/product/b1210850#efficacy-of-gadusol-versus-synthetic-sunscreen-agents-like-oxybenzone>]

---

### Disclaimer & Data Validity:

The information provided in this document is for Research Use Only (RUO) and is strictly not intended for diagnostic or therapeutic procedures. While BenchChem strives to provide accurate protocols, we make no warranties, express or implied, regarding the fitness of this product for every specific experimental setup.

**Technical Support:** The protocols provided are for reference purposes. Unsure if this reagent suits your experiment? [[Contact our Ph.D. Support Team for a compatibility check](#)]

**Need Industrial/Bulk Grade?** [Request Custom Synthesis Quote](#)

## BenchChem

Our mission is to be the trusted global source of essential and advanced chemicals, empowering scientists and researchers to drive progress in science and industry.

### Contact

Address: 3281 E Guasti Rd  
Ontario, CA 91761, United States  
Phone: (601) 213-4426  
Email: [info@benchchem.com](mailto:info@benchchem.com)