

A Comparative Guide to Aha1 Inhibitors: SEW84, KU-177, and HAM-1

Author: BenchChem Technical Support Team. **Date:** December 2025

Compound of Interest

Compound Name: SEW84

Cat. No.: B12397975

[Get Quote](#)

For Researchers, Scientists, and Drug Development Professionals

The co-chaperone Aha1 (Activator of Hsp90 ATPase homolog 1) has emerged as a compelling therapeutic target. By stimulating the ATPase activity of Hsp90, Aha1 plays a crucial role in the folding and activation of a subset of Hsp90 client proteins, many of which are implicated in diseases ranging from cancer to neurodegeneration. Consequently, the development of small molecule inhibitors that specifically target the Hsp90-Aha1 interaction or the Aha1-stimulated ATPase activity offers a more targeted therapeutic strategy with potentially fewer side effects than pan-Hsp90 inhibition. This guide provides a comparative analysis of three such inhibitors: **SEW84**, KU-177, and HAM-1, focusing on their mechanisms of action, biochemical and cellular activities, and the experimental methodologies used for their characterization.

Data Presentation: A Side-by-Side Comparison

The following table summarizes the key quantitative data for **SEW84**, KU-177, and HAM-1, offering a clear comparison of their biochemical properties and cellular effects.

Feature	SEW84	KU-177	HAM-1
Primary Mechanism of Action	Inhibits Aha1-stimulated Hsp90 ATPase activity[1][2][3]	Disrupts the Aha1/Hsp90 protein-protein interaction[4][5]	Inhibits Aha1-stimulated Hsp90 ATPase activity[6][7][8]
Binding Target	C-terminal domain of Aha1[3]	Binds to a site at the Aha1/Hsp90 interface[5]	N-terminal domain of Hsp90[7][8]
IC50 (Aha1-stimulated Hsp90 ATPase activity)	0.3 μ M[1]	Not applicable (does not directly inhibit ATPase activity)	~93% inhibition of Aha1-stimulated activity[6][7]
IC50 (Aha1/Hsp90 Interaction)	Weakens the interaction	4.08 μ M[4]	Does not dissociate the complex[7][8]
Dissociation Constant (Kd)	1.7 μ M (for Aha1)	Not reported	24 μ M (apparent Kd for Hsp90-Aha1 complex)[6]
Effect on Basal Hsp90 ATPase Activity	No significant inhibition[2][3]	No inhibition[4][5]	No significant inhibition[7][8]
Cellular Effects	Reduces phosphorylated tau; Inhibits androgen and glucocorticoid receptor activity[1][3]	Ablates Aha1-driven tau aggregation; Inhibits proliferation of multiple myeloma cells[4][5]	Inhibits mineralocorticoid receptor activity[8]

Experimental Protocols

Detailed methodologies are crucial for the evaluation and comparison of inhibitor performance. Below are generalized protocols for key experiments cited in the characterization of **SEW84**, **KU-177**, and **HAM-1**.

Hsp90 ATPase Activity Assay (Malachite Green-based)

This assay quantifies the amount of inorganic phosphate (Pi) released from ATP hydrolysis by Hsp90, providing a measure of its ATPase activity.

Principle: The malachite green reagent forms a colored complex with free phosphate, which can be measured spectrophotometrically.

Protocol:

- **Reaction Setup:** In a 96-well plate, combine recombinant human Hsp90 (e.g., 2-4 μ M) and Aha1 (e.g., 2-4 μ M) in assay buffer (e.g., 100 mM Tris-HCl pH 7.4, 20 mM KCl, 6 mM MgCl₂).
- **Inhibitor Addition:** Add the test inhibitor (**SEW84**, HAM-1, or vehicle control) at various concentrations.
- **Initiation:** Start the reaction by adding ATP to a final concentration of 1 mM.
- **Incubation:** Incubate the plate at 37°C for a defined period (e.g., 90 minutes), ensuring the reaction remains in the linear range.[\[9\]](#)[\[10\]](#)
- **Termination and Detection:** Stop the reaction and add the malachite green working reagent. After color development (15-20 minutes), measure the absorbance at approximately 620 nm. [\[11\]](#)
- **Data Analysis:** Calculate the amount of Pi released using a phosphate standard curve. Determine the percent inhibition relative to the vehicle control and calculate IC₅₀ values.

Aha1/Hsp90 Interaction Assay (AlphaLISA)

This assay is a bead-based immunoassay used to quantify the interaction between two molecules. It was employed in the characterization of KU-177.[\[5\]](#)

Principle: Donor and acceptor beads are brought into proximity by the binding of the target proteins (Aha1 and Hsp90). Upon laser excitation of the donor bead, a singlet oxygen is generated, which diffuses to the acceptor bead, triggering a chemiluminescent signal.

Protocol:

- **Reagent Preparation:** Use GST-tagged Aha1 and His-tagged Hsp90 α . Prepare AlphaLISA acceptor beads conjugated with an anti-GST antibody and donor beads conjugated with an anti-His antibody.
- **Reaction Setup:** In a 384-well plate, incubate GST-Aha1 and His-Hsp90 α in the presence of the test inhibitor (KU-177 or vehicle control) at various concentrations.
- **Bead Addition:** Add the anti-GST acceptor beads and incubate. Then, add the anti-His donor beads under subdued light.
- **Incubation:** Incubate the plate in the dark at room temperature.
- **Detection:** Read the plate using an AlphaLISA-compatible plate reader.
- **Data Analysis:** Determine the percent inhibition of the interaction signal relative to the vehicle control and calculate IC50 values.

Thioflavin T (ThT) Tau Aggregation Assay

This assay monitors the formation of amyloid-like fibrils, such as aggregated tau, in real-time. It is particularly relevant for inhibitors like KU-177 and **SEW84**, which have been shown to affect tau pathology.^{[3][4]}

Principle: Thioflavin T is a fluorescent dye that exhibits enhanced fluorescence upon binding to the beta-sheet structures characteristic of amyloid fibrils.

Protocol:

- **Reaction Setup:** In a 96-well black, clear-bottom plate, combine recombinant tau protein (e.g., 10-15 μ M) with an aggregation inducer such as heparin (e.g., 2.5-8 μ M) in a suitable buffer (e.g., PBS, pH 6.7).
- **Inhibitor and Dye Addition:** Add the test inhibitor (KU-177, **SEW84**, or vehicle control) at various concentrations and Thioflavin T (e.g., 10-50 μ M).
- **Incubation and Monitoring:** Incubate the plate at 37°C with continuous shaking in a plate reader.^{[1][2]} Measure the fluorescence intensity at regular intervals (e.g., every 15 minutes) with excitation around 440 nm and emission around 485 nm.^{[1][2][4]}

- Data Analysis: Plot the fluorescence intensity over time to generate aggregation curves. Compare the lag time, slope, and final fluorescence intensity between the inhibitor-treated and control samples to assess the inhibitory effect.

Mandatory Visualization

The following diagrams, generated using Graphviz, illustrate key concepts related to Aha1 inhibition.

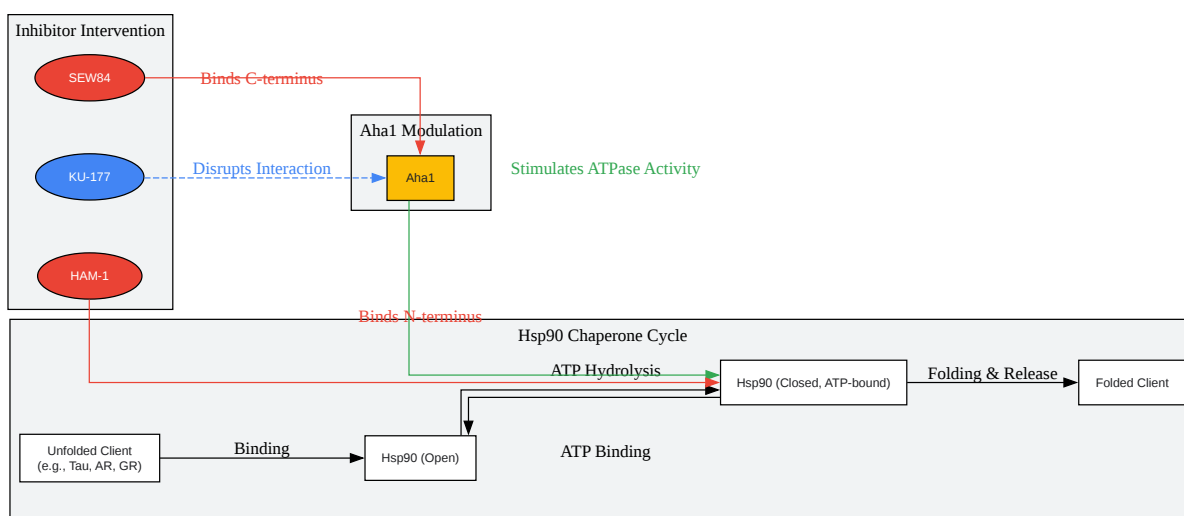

[Click to download full resolution via product page](#)

Caption: Hsp90-Aha1 signaling pathway and points of inhibitor intervention.

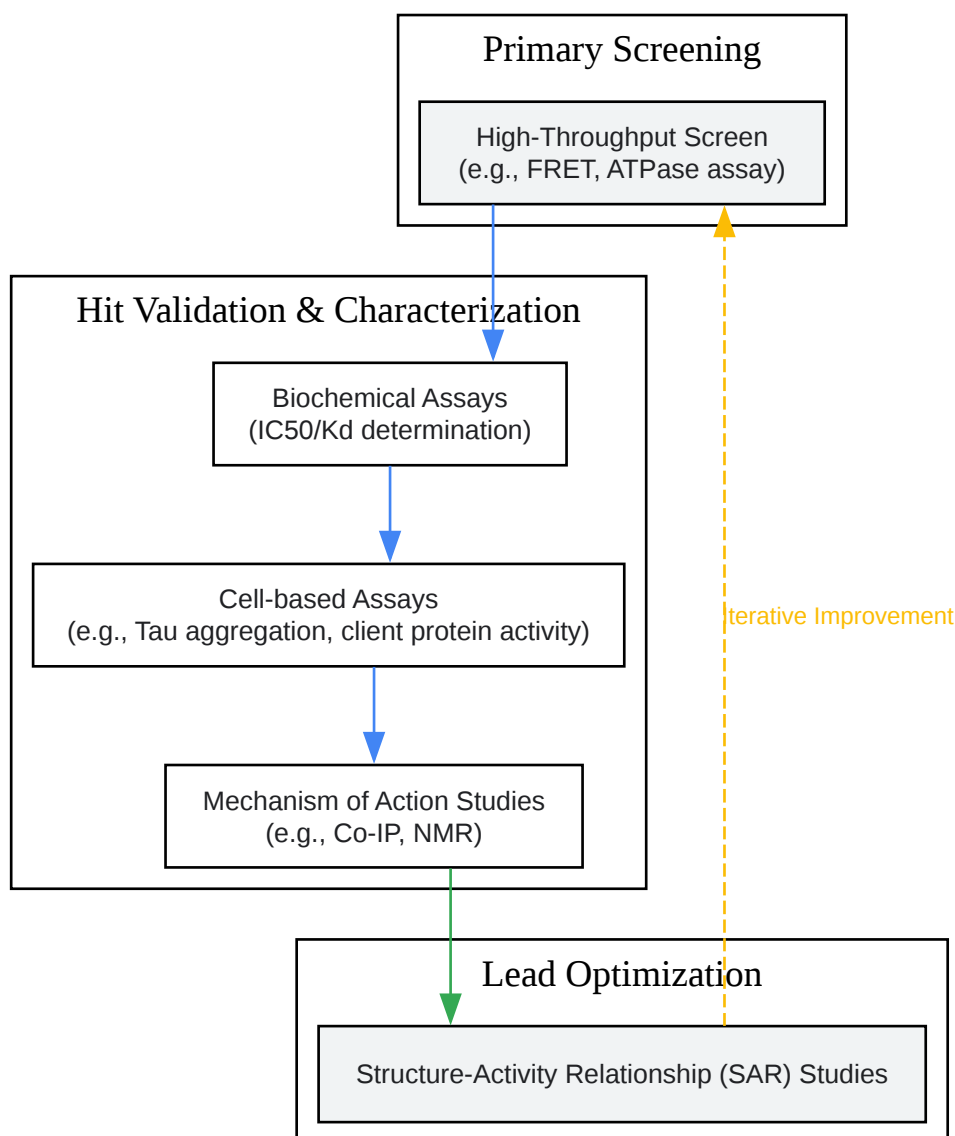

[Click to download full resolution via product page](#)

Caption: Generalized workflow for the discovery and characterization of Aha1 inhibitors.

Need Custom Synthesis?

BenchChem offers custom synthesis for rare earth carbides and specific isotopic labeling.

Email: info@benchchem.com or [Request Quote Online](#).

References

- 1. Tau Protein Thioflavin T Assay | StressMarq | StressMarq Biosciences Inc. [stressmarq.com]
- 2. Tau aggregation monitored by thioflavin-T (ThT) fluorescence in a plate reader [protocols.io]
- 3. alzdiscovery.org [alzdiscovery.org]
- 4. benchchem.com [benchchem.com]
- 5. Synthesis and Evaluation of Small Molecule Disruptors of the Aha1/Hsp90 Complex for the Reduction of Tau Aggregation - PMC [[pmc.ncbi.nlm.nih.gov](https://pubmed.ncbi.nlm.nih.gov/31111111/)]
- 6. In Vitro Aggregation Assays Using Hyperphosphorylated Tau Protein - PMC [[pmc.ncbi.nlm.nih.gov](https://pubmed.ncbi.nlm.nih.gov/31111111/)]
- 7. pubs.acs.org [pubs.acs.org]
- 8. A chemical compound inhibiting the Aha1–Hsp90 chaperone complex - PMC [[pmc.ncbi.nlm.nih.gov](https://pubmed.ncbi.nlm.nih.gov/31111111/)]
- 9. Biological and Structural Basis for Aha1 Regulation of Hsp90 ATPase Activity in Maintaining Proteostasis in the Human Disease Cystic Fibrosis - PMC [[pmc.ncbi.nlm.nih.gov](https://pubmed.ncbi.nlm.nih.gov/31111111/)]
- 10. researchgate.net [researchgate.net]
- 11. benchchem.com [benchchem.com]
- To cite this document: BenchChem. [A Comparative Guide to Aha1 Inhibitors: SEW84, KU-177, and HAM-1]. BenchChem, [2025]. [Online PDF]. Available at: [<https://www.benchchem.com/product/b12397975#comparing-sew84-with-other-aha1-inhibitors-e-g-ku-177-ham-1>]

Disclaimer & Data Validity:

The information provided in this document is for Research Use Only (RUO) and is strictly not intended for diagnostic or therapeutic procedures. While BenchChem strives to provide accurate protocols, we make no warranties, express or implied, regarding the fitness of this product for every specific experimental setup.

Technical Support: The protocols provided are for reference purposes. Unsure if this reagent suits your experiment? [[Contact our Ph.D. Support Team for a compatibility check](#)]

Need Industrial/Bulk Grade? [Request Custom Synthesis Quote](#)

BenchChem

Our mission is to be the trusted global source of essential and advanced chemicals, empowering scientists and researchers to drive progress in science and industry.

Contact

Address: 3281 E Guasti Rd

Ontario, CA 91761, United States

Phone: (601) 213-4426

Email: info@benchchem.com