

A Comparative Analysis of PROTAC BRD9 Degradar-1 and dBRD9

Author: BenchChem Technical Support Team. **Date:** December 2025

Compound of Interest

Compound Name: PROTAC BRD9 Degradar-1

Cat. No.: B2880809

[Get Quote](#)

In the rapidly evolving field of targeted protein degradation, PROTACs (Proteolysis Targeting Chimeras) have emerged as a powerful modality to eliminate disease-causing proteins. Among the targets of interest is Bromodomain-containing protein 9 (BRD9), a subunit of the BAF (SWI/SNF) chromatin remodeling complex implicated in various cancers. This guide provides a comparative analysis of two prominent BRD9-targeting PROTACs: **PROTAC BRD9 Degradar-1** and dBRD9. Both molecules are designed to hijack the cell's ubiquitin-proteasome system to selectively degrade BRD9, but they exhibit distinct performance characteristics. This analysis is intended for researchers, scientists, and drug development professionals seeking to understand the nuances of these two important research tools.

Performance Comparison

While a direct head-to-head study under identical experimental conditions is not publicly available, we can compile and compare the performance data from various sources. It is crucial to note that variations in cell lines, treatment times, and assay conditions can influence the observed potency and efficacy.

Table 1: Quantitative Performance Data for **PROTAC BRD9 Degradar-1** and dBRD9

Parameter	PROTAC BRD9 Degradar-1	dBRD9	Source
Binding Affinity (IC50 to BRD9)	13.5 nM[1]	Not explicitly stated for the PROTAC, but the warhead is a known BRD9 inhibitor.	[1]
Degradation Potency (DC50)	Not explicitly stated	90 nM (in HEK293 cells)[2]	[2]
E3 Ligase Recruited	Cereblon (CRBN)[1]	Cereblon (CRBN)[3]	[1][3]
Cell Line(s) Tested	Not explicitly stated in available abstracts	HEK293[2], MOLM-13[3]	[2][3]
Selectivity	Inhibits BRD4 at 3.78 μ M[1]	Does not degrade BRD4 or BRD7 at concentrations up to 5 μ M[3]	[1][3]

Mechanism of Action and Downstream Effects

Both **PROTAC BRD9 Degradar-1** and dBRD9 function by inducing the formation of a ternary complex between BRD9 and the E3 ubiquitin ligase Cereblon. This proximity leads to the polyubiquitination of BRD9, marking it for degradation by the proteasome.

The degradation of BRD9 has been shown to impact several key cellular processes:

- **Ribosome Biogenesis:** Depletion of BRD9 downregulates genes involved in ribosome biogenesis.[4]
- **MYC Signaling:** The expression of the master regulator MYC is decreased following BRD9 degradation.[4]
- **Cell Cycle Progression:** BRD9 degradation can lead to cell cycle arrest.[5]
- **Inflammation and Immune Response:** Signaling pathways associated with inflammation and immune response are affected.[5]

- DNA Repair: Pathways involved in DNA repair are also modulated by the loss of BRD9.[5]

Experimental Methodologies

The following are detailed protocols for key experiments typically used to characterize and compare PROTAC degraders.

Western Blotting for BRD9 Degradation

This protocol is a standard method to quantify the reduction of a target protein in cells following treatment with a degrader.

- Cell Culture and Treatment: Plate cells (e.g., MOLM-13) at a suitable density and allow them to adhere overnight. Treat the cells with a dose-response of the PROTAC (e.g., 1 nM to 10 μ M) or vehicle control (DMSO) for a specified time (e.g., 2, 4, 8, 24 hours).
- Cell Lysis: Wash the cells with ice-cold PBS and lyse them in RIPA buffer supplemented with protease and phosphatase inhibitors.
- Protein Quantification: Determine the protein concentration of each lysate using a BCA or Bradford protein assay.
- SDS-PAGE and Western Blotting:
 - Load equal amounts of protein (e.g., 20-30 μ g) onto an SDS-PAGE gel.
 - Separate the proteins by electrophoresis.
 - Transfer the separated proteins to a PVDF or nitrocellulose membrane.
 - Block the membrane with 5% non-fat milk or BSA in TBST for 1 hour at room temperature.
 - Incubate the membrane with a primary antibody against BRD9 overnight at 4°C. A loading control antibody (e.g., GAPDH, β -actin) should also be used.
 - Wash the membrane with TBST and incubate with a horseradish peroxidase (HRP)-conjugated secondary antibody for 1 hour at room temperature.

- Wash the membrane again and detect the signal using an enhanced chemiluminescence (ECL) substrate and an imaging system.
- Data Analysis: Quantify the band intensities using densitometry software. Normalize the BRD9 signal to the loading control and then to the vehicle-treated control to determine the percentage of remaining protein. The DC50 value (the concentration at which 50% of the protein is degraded) can be calculated from the dose-response curve.

Cell Viability Assay (MTT Assay)

This assay measures the metabolic activity of cells as an indicator of cell viability and proliferation.

- Cell Seeding: Seed cells in a 96-well plate at a density of 5,000-10,000 cells per well and allow them to attach overnight.
- Compound Treatment: Treat the cells with a serial dilution of the PROTAC or vehicle control and incubate for a desired period (e.g., 72 hours).
- MTT Addition: Add MTT (3-(4,5-dimethylthiazol-2-yl)-2,5-diphenyltetrazolium bromide) solution to each well to a final concentration of 0.5 mg/mL and incubate for 2-4 hours at 37°C.
- Formazan Solubilization: Remove the medium and add DMSO or a solubilization buffer to dissolve the formazan crystals.
- Absorbance Measurement: Measure the absorbance at 570 nm using a microplate reader.
- Data Analysis: Calculate the percentage of cell viability relative to the vehicle-treated control. The IC50 value (the concentration at which 50% of cell growth is inhibited) can be determined from the dose-response curve.

In-Cell Ubiquitination Assay (NanoBRET™ Assay)

This assay allows for the real-time measurement of target protein ubiquitination in live cells.

- Cell Engineering: Co-transfect cells (e.g., HEK293) with plasmids expressing the target protein (BRD9) fused to a NanoLuc® luciferase and a HaloTag®-ubiquitin fusion protein.

- **Cell Plating and Labeling:** Plate the transfected cells in a 96-well plate. Add a fluorescent HaloTag® ligand to the cells to label the ubiquitin.
- **PROTAC Treatment:** Add the PROTAC degrader at various concentrations to the cells.
- **BRET Measurement:** Add the NanoBRET™ substrate and measure the bioluminescence resonance energy transfer (BRET) signal using a luminometer. The BRET signal is generated when the NanoLuc® donor on BRD9 is in close proximity to the fluorescently labeled ubiquitin acceptor, indicating ubiquitination.
- **Data Analysis:** The increase in the BRET signal corresponds to an increase in BRD9 ubiquitination. This can be monitored over time and at different PROTAC concentrations.

Visualizing the Mechanism and Workflow

To better illustrate the underlying processes, the following diagrams have been generated using the DOT language.

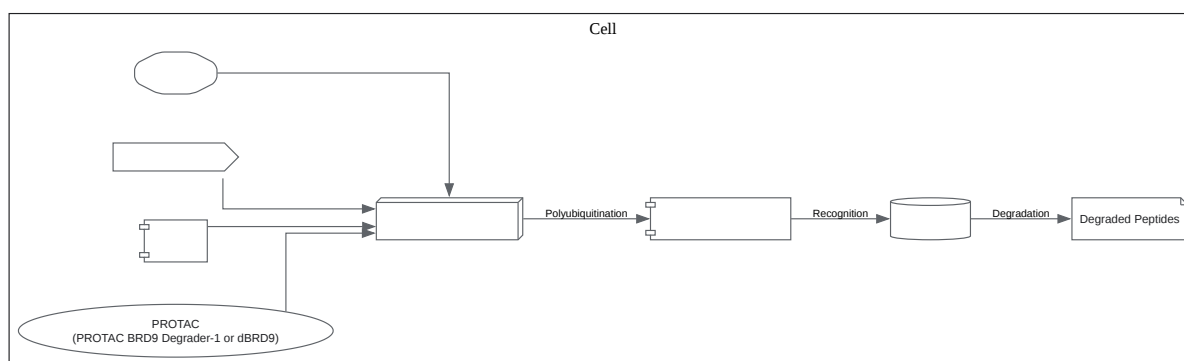

[Click to download full resolution via product page](#)

Caption: Mechanism of Action for BRD9 PROTACs.

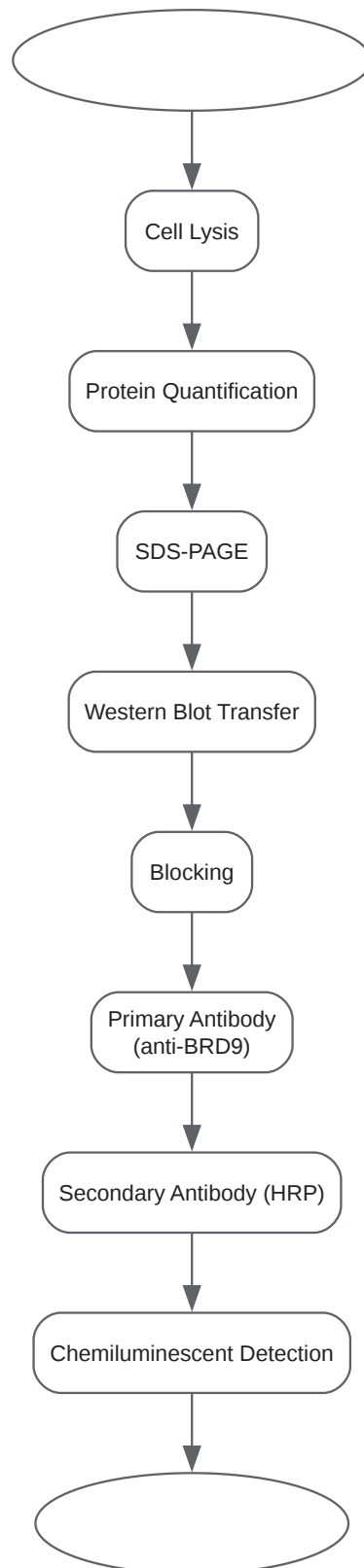

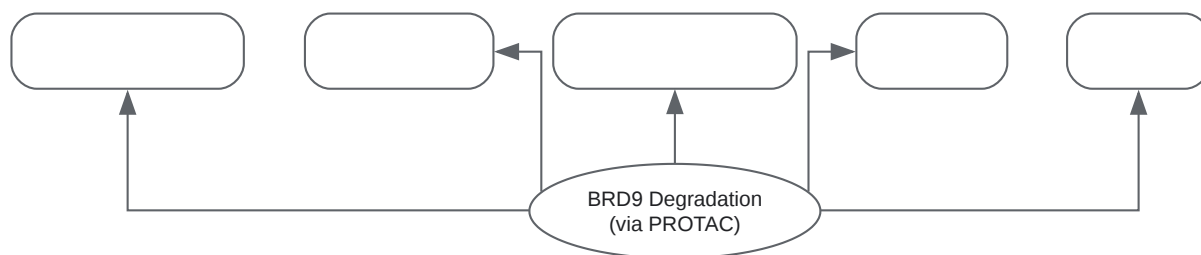

[Click to download full resolution via product page](#)

Need Custom Synthesis?

BenchChem offers custom synthesis for rare earth carbides and specific isotopic labeling.

Email: info@benchchem.com or [Request Quote Online](#).

References

- 1. medchemexpress.com [medchemexpress.com]
- 2. DBr-1 | DCAF1-BRD9 PROTAC | Probechem Biochemicals [probechem.com]
- 3. dBRD9 | Active Degraders | Tocris Bioscience [toocris.com]
- 4. BRD9 Degradation Disrupts Ribosome Biogenesis in Multiple Myeloma - PMC [pmc.ncbi.nlm.nih.gov]
- 5. BRD9 degraders as chemosensitizers in acute leukemia and multiple myeloma - PMC [pmc.ncbi.nlm.nih.gov]
- To cite this document: BenchChem. [A Comparative Analysis of PROTAC BRD9 Degradation-1 and dBRD9]. BenchChem, [2025]. [Online PDF]. Available at: [https://www.benchchem.com/product/b2880809#protac-brd9-degrader-1-vs-dbrd9-a-comparative-analysis]

Disclaimer & Data Validity:

The information provided in this document is for Research Use Only (RUO) and is strictly not intended for diagnostic or therapeutic procedures. While BenchChem strives to provide

accurate protocols, we make no warranties, express or implied, regarding the fitness of this product for every specific experimental setup.

Technical Support: The protocols provided are for reference purposes. Unsure if this reagent suits your experiment? [[Contact our Ph.D. Support Team for a compatibility check](#)]

Need Industrial/Bulk Grade? [Request Custom Synthesis Quote](#)

BenchChem

Our mission is to be the trusted global source of essential and advanced chemicals, empowering scientists and researchers to drive progress in science and industry.

Contact

Address: 3281 E Guasti Rd

Ontario, CA 91761, United States

Phone: (601) 213-4426

Email: info@benchchem.com