

A Comparative Analysis of Gefitinib Activity on the EGFR Signaling Pathway Across Species

Author: BenchChem Technical Support Team. **Date:** December 2025

Compound of Interest

Compound Name: C5a Receptor agonist, W5Cha

Cat. No.: B15608044

[Get Quote](#)

For Researchers, Scientists, and Drug Development Professionals

This guide provides a comparative overview of the activity of Gefitinib, a selective inhibitor of the epidermal growth factor receptor (EGFR) tyrosine kinase, in cells from different species.^[1] Gefitinib competitively binds to the ATP-binding site of the EGFR tyrosine kinase domain, inhibiting autophosphorylation and subsequent downstream signaling, which can lead to the inhibition of cell proliferation and induction of apoptosis in cancer cells.^{[2][3]} This document summarizes key experimental data, details relevant protocols, and visualizes the associated biological pathways to support research and development efforts.

Comparative Activity of Gefitinib (IC50)

The half-maximal inhibitory concentration (IC50) is a critical measure of a drug's potency. The following table summarizes the IC50 values of Gefitinib in various cancer cell lines from different species, highlighting the differential sensitivity.

Cell Line	Species	Cancer Type	IC50 (μM)	Reference
HCC827	Human	Non-Small Cell Lung Cancer	0.013	[4]
PC-9	Human	Non-Small Cell Lung Cancer	0.077	[4]
H3255	Human	Non-Small Cell Lung Cancer	0.003	[5]
11-18	Human	Non-Small Cell Lung Cancer	0.39	[5]
H1975	Human	Non-Small Cell Lung Cancer	4.4 - 25.5	[6]
A549	Human	Lung Adenocarcinoma	19.91	[7]
NR6M	Mouse	Fibroblast (EGFR-mutant)	0.43	[8]
NR6W	Mouse	Fibroblast (EGFR wild-type)	0.027	[8]
BALB-NeuT	Mouse	Mammary Carcinoma (in vivo)	Not specified	[9]
(Model)	Rat	Hepatocarcinogenesis (in vivo)	Not specified	[10]

Note: IC50 values can vary based on experimental conditions. The data presented here is for comparative purposes. In vivo studies in mice and rats demonstrated efficacy in reducing tumor progression but did not specify IC50 values.[9][10]

Experimental Protocols

A standardized protocol is crucial for the reproducible assessment of drug efficacy. The following is a detailed methodology for determining the IC50 of Gefitinib using a Thiazolyl Blue

Tetrazolium Bromide (MTT) assay, a common colorimetric assay for assessing cell metabolic activity.[11][12]

Objective: To determine the concentration of Gefitinib that inhibits 50% of cell growth (IC50) in a specific cell line.

Materials:

- Target adherent cell line
- Complete cell culture medium (e.g., DMEM with 10% FBS)
- Gefitinib stock solution (in DMSO)
- 96-well cell culture plates
- MTT (3-(4,5-dimethylthiazol-2-yl)-2,5-diphenyltetrazolium bromide) solution (5 mg/mL in PBS)[12][13]
- DMSO (Dimethyl sulfoxide)
- Phosphate-Buffered Saline (PBS)
- Multichannel pipette
- Microplate reader

Procedure:

- Cell Seeding:
 - Harvest and count cells in the logarithmic growth phase.
 - Seed the cells in a 96-well plate at a density of 3,500 cells/well in 100 μ L of complete medium.[13]
 - Incubate the plate overnight at 37°C in a humidified atmosphere with 5% CO₂ to allow for cell attachment.[13]

- Drug Treatment:
 - Prepare serial dilutions of Gefitinib from the stock solution in the complete culture medium. A typical concentration range might be 0.01 to 30 $\mu\text{mol/L}$.[\[13\]](#)
 - Remove the old medium from the wells and add 100 μL of the medium containing the different concentrations of Gefitinib. Include a vehicle control (medium with DMSO) and a blank (medium only).
 - Incubate the plate for 48 hours at 37°C and 5% CO₂.[\[13\]](#)
- MTT Assay:
 - After the incubation period, add 20 μL of MTT solution (5 mg/mL) to each well.[\[13\]](#)
 - Incubate the plate for an additional 4 hours at 37°C.[\[13\]](#)
 - Carefully remove the medium containing MTT.
 - Add 150 μL of DMSO to each well to dissolve the formazan crystals.[\[13\]](#)
 - Shake the plate on an orbital shaker for 15 minutes to ensure complete dissolution.[\[12\]](#)
- Data Acquisition and Analysis:
 - Measure the absorbance of each well at a wavelength of 570 nm using a microplate reader.[\[13\]](#)
 - The percentage of cell viability is calculated using the following formula: (Absorbance of treated cells / Absorbance of control cells) x 100
 - The IC₅₀ value is determined by plotting the percentage of cell viability against the logarithm of the Gefitinib concentration and fitting the data to a dose-response curve.

Visualizing Molecular Interactions and Workflows

EGFR Signaling Pathway

The Epidermal Growth Factor Receptor (EGFR) is a transmembrane protein that, upon binding to ligands such as EGF, activates several downstream signaling cascades.[14] These pathways, including the RAS-RAF-MEK-ERK and PI3K-AKT-mTOR pathways, are crucial for regulating cell proliferation, survival, and differentiation.[15][16] Gefitinib inhibits the initial step of this cascade by blocking the tyrosine kinase activity of EGFR.[3]

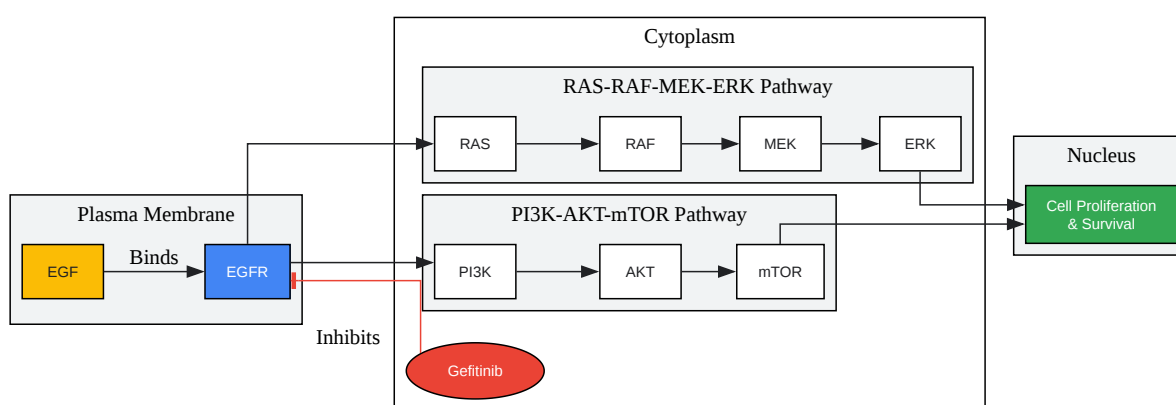

[Click to download full resolution via product page](#)

Caption: EGFR signaling cascade and the inhibitory action of Gefitinib.

Experimental Workflow for IC50 Determination

The process of determining the IC50 value for a compound like Gefitinib involves a series of sequential steps, from cell culture preparation to data analysis. This workflow ensures that the results are reliable and reproducible.

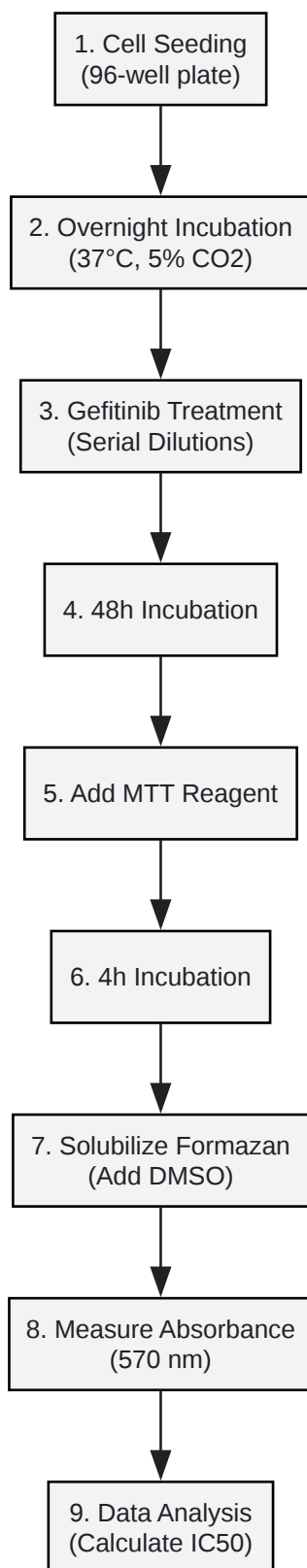

[Click to download full resolution via product page](#)

Caption: Workflow for determining IC₅₀ using the MTT assay.

Need Custom Synthesis?

BenchChem offers custom synthesis for rare earth carbides and specific isotopic labeling.

Email: info@benchchem.com or [Request Quote Online](#).

References

- 1. go.drugbank.com [go.drugbank.com]
- 2. Review of the Treatment of Non-Small Cell Lung Cancer with Gefitinib - PMC [pmc.ncbi.nlm.nih.gov]
- 3. Gefitinib: mechanism of action, pharmacokinetics and side effect_Chemicalbook [chemicalbook.com]
- 4. researchgate.net [researchgate.net]
- 5. researchgate.net [researchgate.net]
- 6. Molecular mechanism of action and potential biomarkers of growth inhibition of synergistic combination of afatinib and dasatinib against gefitinib-resistant non-small cell lung cancer cells - PMC [pmc.ncbi.nlm.nih.gov]
- 7. researchgate.net [researchgate.net]
- 8. selleckchem.com [selleckchem.com]
- 9. Gefitinib prevents cancer progression in mice expressing the activated rat HER2/neu - PubMed [pubmed.ncbi.nlm.nih.gov]
- 10. mdpi.com [mdpi.com]
- 11. Cell Viability Assays - Assay Guidance Manual - NCBI Bookshelf [ncbi.nlm.nih.gov]
- 12. MTT assay protocol | Abcam [abcam.com]
- 13. MTT assay and estimation of half-maximal inhibitory concentration (IC50) values [bio-protocol.org]
- 14. creative-diagnostics.com [creative-diagnostics.com]
- 15. researchgate.net [researchgate.net]
- 16. ClinPGx [clinpgx.org]
- To cite this document: BenchChem. [A Comparative Analysis of Gefitinib Activity on the EGFR Signaling Pathway Across Species]. BenchChem, [2025]. [Online PDF]. Available at:

[<https://www.benchchem.com/product/b15608044#w5cha-activity-in-cells-from-different-species>]

Disclaimer & Data Validity:

The information provided in this document is for Research Use Only (RUO) and is strictly not intended for diagnostic or therapeutic procedures. While BenchChem strives to provide accurate protocols, we make no warranties, express or implied, regarding the fitness of this product for every specific experimental setup.

Technical Support: The protocols provided are for reference purposes. Unsure if this reagent suits your experiment? [[Contact our Ph.D. Support Team for a compatibility check](#)]

Need Industrial/Bulk Grade? [Request Custom Synthesis Quote](#)

BenchChem

Our mission is to be the trusted global source of essential and advanced chemicals, empowering scientists and researchers to drive progress in science and industry.

Contact

Address: 3281 E Guasti Rd
Ontario, CA 91761, United States
Phone: (601) 213-4426
Email: info@benchchem.com