

A Comparative Analysis of BB2-50F and Other Key Anti-Tuberculosis Agents

Author: BenchChem Technical Support Team. **Date:** December 2025

Compound of Interest

Compound Name: *BB2-50F*

Cat. No.: *B12365362*

[Get Quote](#)

For Researchers, Scientists, and Drug Development Professionals

The emergence of multidrug-resistant (MDR) and extensively drug-resistant (XDR) strains of *Mycobacterium tuberculosis* (Mtb) necessitates the urgent development of novel therapeutics. This guide provides a comparative overview of the novel anti-tuberculosis candidate, **BB2-50F**, alongside key contemporary tuberculosis drugs: Bedaquiline, Delamanid, Pretomanid, Sutezolid, and Linezolid. This comparison focuses on efficacy, mechanism of action, and the experimental protocols used for their evaluation.

Efficacy Against *Mycobacterium tuberculosis* H37Rv

The in vitro efficacy of anti-tuberculosis agents is commonly determined by their Minimum Inhibitory Concentration (MIC), the lowest concentration of a drug that prevents visible growth of a microorganism. The following table summarizes the MIC values of **BB2-50F** and comparator drugs against the reference strain *M. tuberculosis* H37Rv.

Drug	Drug Class	Target(s)	MIC ($\mu\text{g/mL}$)	MIC (μM)
BB2-50F	6-substituted 5-(N,N-hexamethylene)amiloride derivative	Succinate dehydrogenase & F1Fo-ATP synthase	-	8[1]
Bedaquiline	Diarylquinoline	F1Fo-ATP synthase (atpE subunit)	0.015 - 0.12[2][3]	~0.027 - 0.21
Delamanid	Nitroimidazole	Mycolic acid synthesis (via F420 cofactor system)	0.002 - 0.012[4]	~0.003 - 0.02
Pretomanid	Nitroimidazole	Mycolic acid synthesis & respiratory poisoning	0.06 - 0.25[5]	~0.14 - 0.59
Sutezolid	Oxazolidinone	Protein synthesis (50S ribosomal subunit)	\leq 0.0625 - 0.5[6]	\leq 0.18 - 1.41
Linezolid	Oxazolidinone	Protein synthesis (50S ribosomal subunit)	0.25 - 1.0[7][8]	~0.74 - 2.97

Note: MIC values can vary based on the specific experimental method (e.g., broth microdilution vs. agar dilution) and media used.

Mechanisms of Action and Associated Pathways

The following diagrams illustrate the mechanisms of action for **BB2-50F** and the comparator drugs.

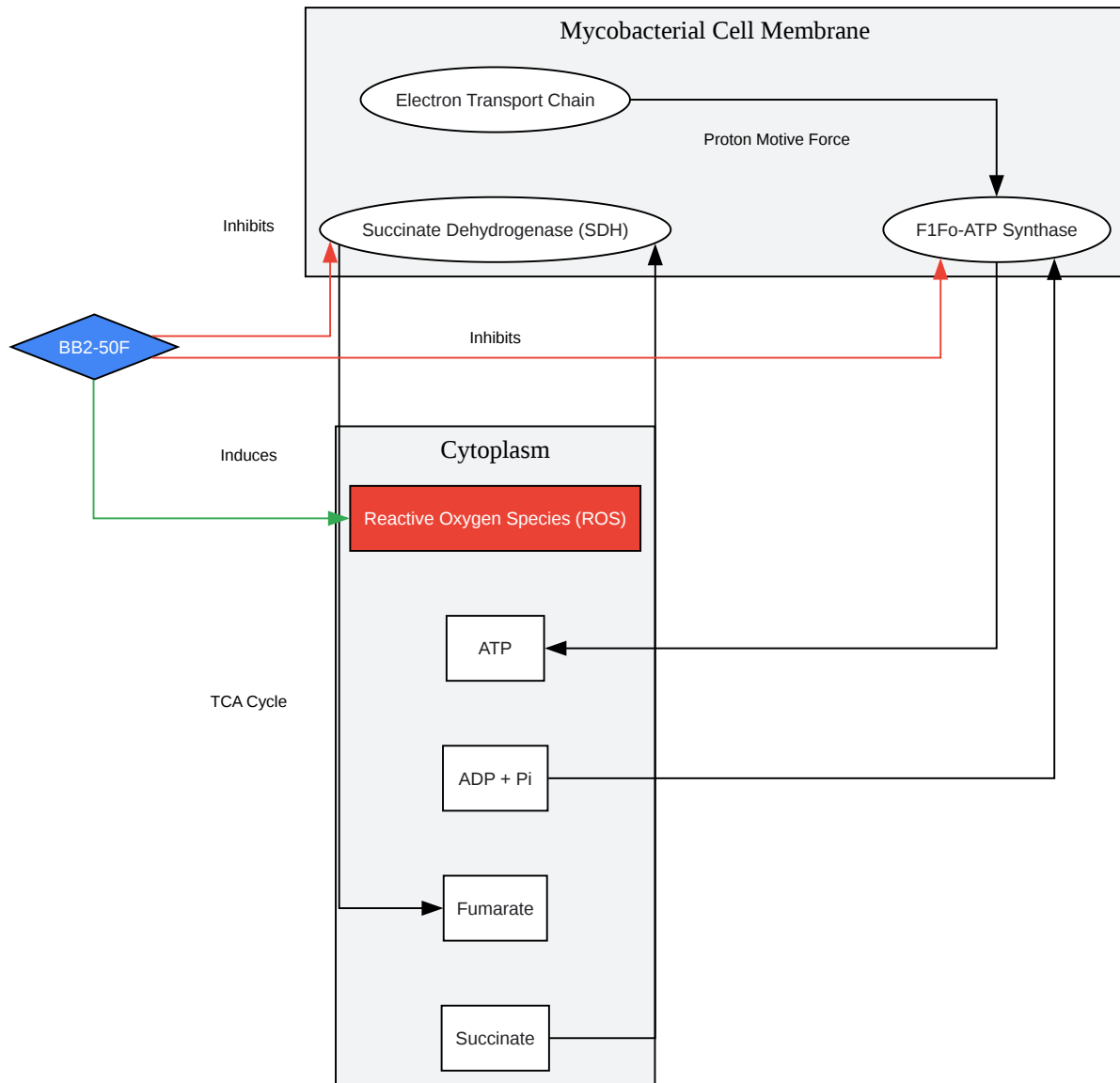

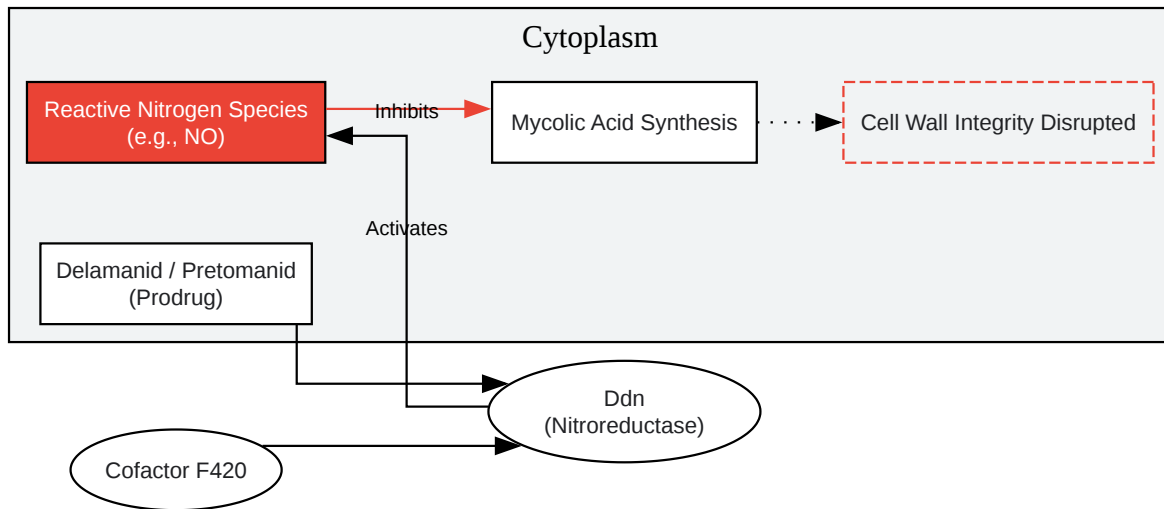
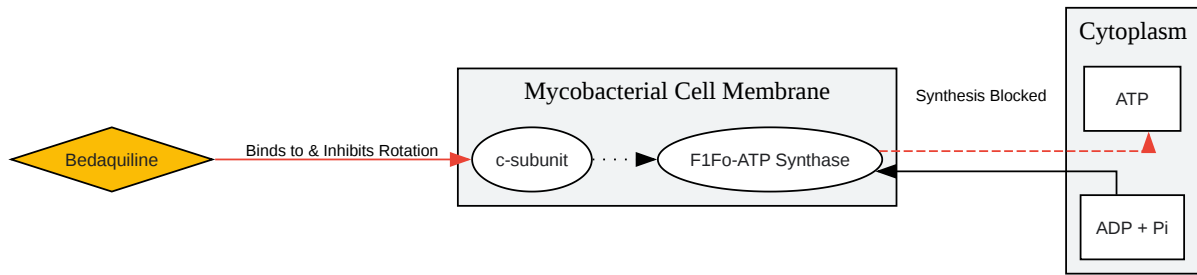

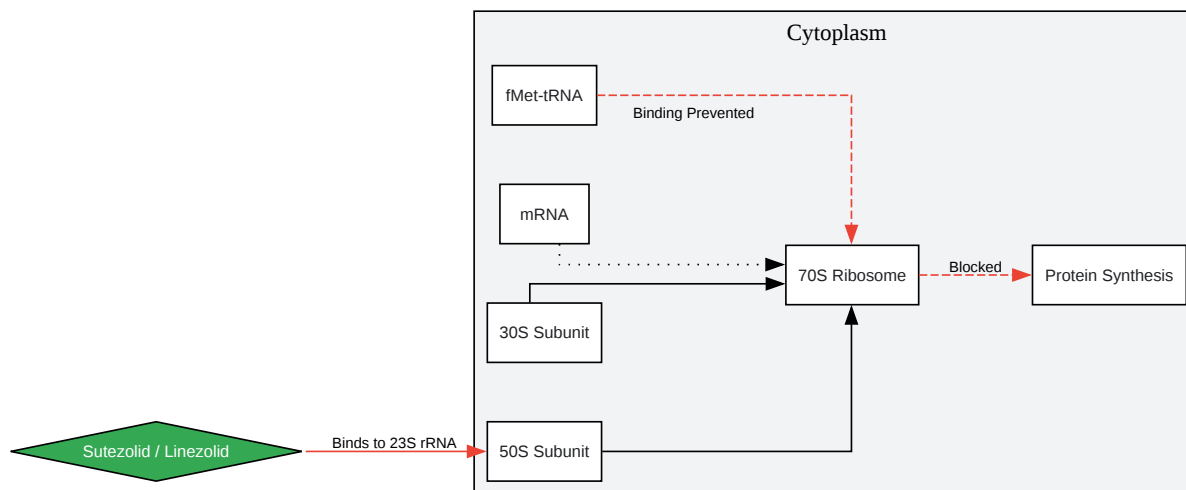

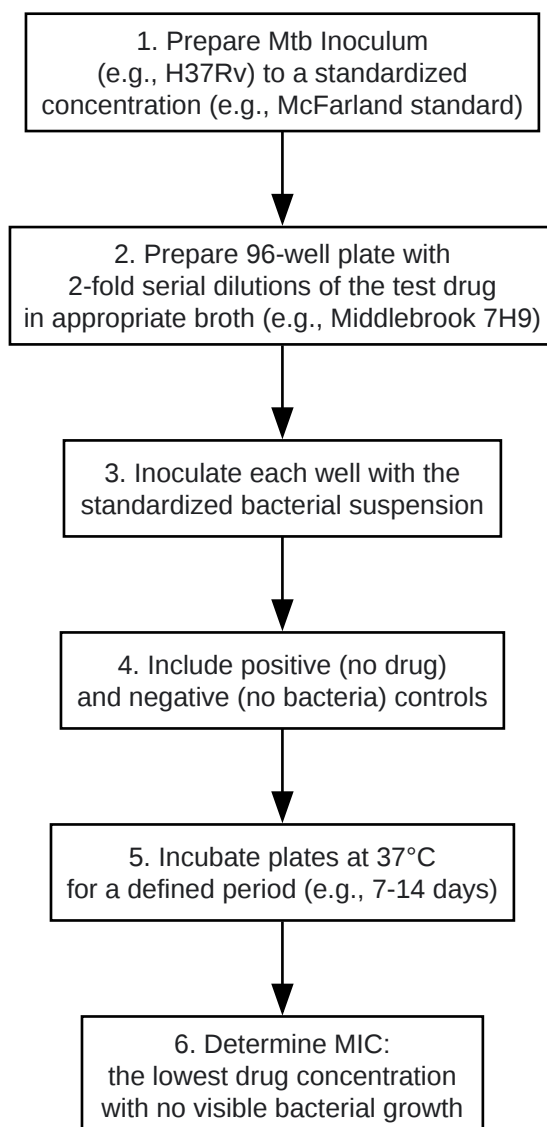

[Click to download full resolution via product page](#)

Need Custom Synthesis?

BenchChem offers custom synthesis for rare earth carbides and specific isotopic labeling.

Email: info@benchchem.com or [Request Quote Online](#).

References

- 1. academic.oup.com [academic.oup.com]

- 2. A Multilaboratory, Multicountry Study To Determine Bedaquiline MIC Quality Control Ranges for Phenotypic Drug Susceptibility Testing - PMC [[pmc.ncbi.nlm.nih.gov](https://pubmed.ncbi.nlm.nih.gov/)]
- 3. [researchgate.net](https://www.researchgate.net/) [[researchgate.net](https://www.researchgate.net/)]
- 4. MIC of Delamanid (OPC-67683) against Mycobacterium tuberculosis Clinical Isolates and a Proposed Critical Concentration - PMC [[pmc.ncbi.nlm.nih.gov](https://pubmed.ncbi.nlm.nih.gov/)]
- 5. Ancient and recent differences in the intrinsic susceptibility of Mycobacterium tuberculosis complex to pretomanid - PMC [[pmc.ncbi.nlm.nih.gov](https://pubmed.ncbi.nlm.nih.gov/)]
- 6. New Oxazolidinones for Tuberculosis: Are Novel Treatments on the Horizon? - PMC [[pmc.ncbi.nlm.nih.gov](https://pubmed.ncbi.nlm.nih.gov/)]
- 7. Linezolid Kills Acid-Phase and Nonreplicative-Persister-Phase Mycobacterium tuberculosis in a Hollow-Fiber Infection Model - PMC [[pmc.ncbi.nlm.nih.gov](https://pubmed.ncbi.nlm.nih.gov/)]
- 8. In Vitro Activities of Linezolid against Clinical Isolates of Mycobacterium tuberculosis That Are Susceptible or Resistant to First-Line Antituberculous Drugs - PMC [[pmc.ncbi.nlm.nih.gov](https://pubmed.ncbi.nlm.nih.gov/)]
- To cite this document: BenchChem. [A Comparative Analysis of BB2-50F and Other Key Anti-Tuberculosis Agents]. BenchChem, [2025]. [Online PDF]. Available at: [<https://www.benchchem.com/product/b12365362#comparing-bb2-50f-efficacy-to-other-tb-drugs>]

Disclaimer & Data Validity:

The information provided in this document is for Research Use Only (RUO) and is strictly not intended for diagnostic or therapeutic procedures. While BenchChem strives to provide accurate protocols, we make no warranties, express or implied, regarding the fitness of this product for every specific experimental setup.

Technical Support: The protocols provided are for reference purposes. Unsure if this reagent suits your experiment? [[Contact our Ph.D. Support Team for a compatibility check](#)]

Need Industrial/Bulk Grade? [Request Custom Synthesis Quote](#)

BenchChem

Our mission is to be the trusted global source of essential and advanced chemicals, empowering scientists and researchers to drive progress in science and industry.

Contact

Address: 3281 E Guasti Rd

Ontario, CA 91761, United States

Phone: (601) 213-4426

Email: info@benchchem.com