

A-1070722 for PET Imaging of Glycogen Synthase Kinase-3 (GSK-3)

Author: BenchChem Technical Support Team. **Date:** December 2025

Compound of Interest

Compound Name: A 1070722

Cat. No.: B605029

[Get Quote](#)

Application Notes and Protocols for Researchers and Drug Development Professionals

Introduction

Glycogen Synthase Kinase-3 (GSK-3) is a serine/threonine kinase implicated in the pathophysiology of numerous diseases, including Alzheimer's disease, Parkinson's disease, diabetes, and cancer.^{[1][2][3][4][5]} The ability to non-invasively quantify GSK-3 in the brain offers a significant opportunity to understand its role in these disorders and to facilitate the development of novel therapeutics. A-1070722 is a potent and selective inhibitor of GSK-3 that has been successfully radiolabeled with carbon-11 (¹¹C]A-1070722) for use as a positron emission tomography (PET) tracer.^{[1][2][3][4][5]} These application notes provide a comprehensive overview of the properties of [¹¹C]A-1070722 and detailed protocols for its use in preclinical PET imaging studies.

Quantitative Data Summary

The following tables summarize the key quantitative data for the [¹¹C]A-1070722 PET tracer.

Table 1: In Vitro Binding Affinity and Selectivity of A-1070722^[1]

Target	K _i (nM)	Selectivity
GSK-3 α/β	0.6	>50-fold against a panel of other kinases

Table 2: Radiosynthesis of [¹¹C]A-1070722[1]

Parameter	Value
Precursor	Desmethyl-A-1070722
Radiochemical Yield	40 ± 5%
Radiochemical Purity	>97%
Molar Activity	88.8 ± 15 GBq/μmol

Table 3: In Vivo Performance of [¹¹C]A-1070722 in Vervet Monkeys[1]

Parameter	Value
Blood-Brain Barrier Penetration	Yes
Unmetabolized [¹¹ C]A-1070722 in Plasma (at 30 min)	45.1 ± 12.9%
Unmetabolized [¹¹ C]A-1070722 in Plasma (at 90 min)	20.1 ± 9.5%

Table 4: Regional Distribution Volume (V_t) of [¹¹C]A-1070722 in Vervet Monkey Brain[1]

Brain Region	V_t (2-Tissue Compartment Model)	V_t (Logan Plot)
Frontal Cortex	~2.2	~2.1
Parietal Cortex	~2.1	~2.0
Anterior Cingulate	~2.0	~1.9
Cerebellum	~1.9	~1.8
Occipital Cortex	~1.8	~1.7
Hippocampus	~1.7	~1.6
Amygdala	~1.6	~1.5
Thalamus	~1.5	~1.4
Caudate	~1.4	~1.3
Putamen	~1.4	~1.3
Cerebral Gray Matter	~1.8	~1.7
Cerebral White Matter	~1.7	~1.6

Signaling Pathway and Experimental Workflow

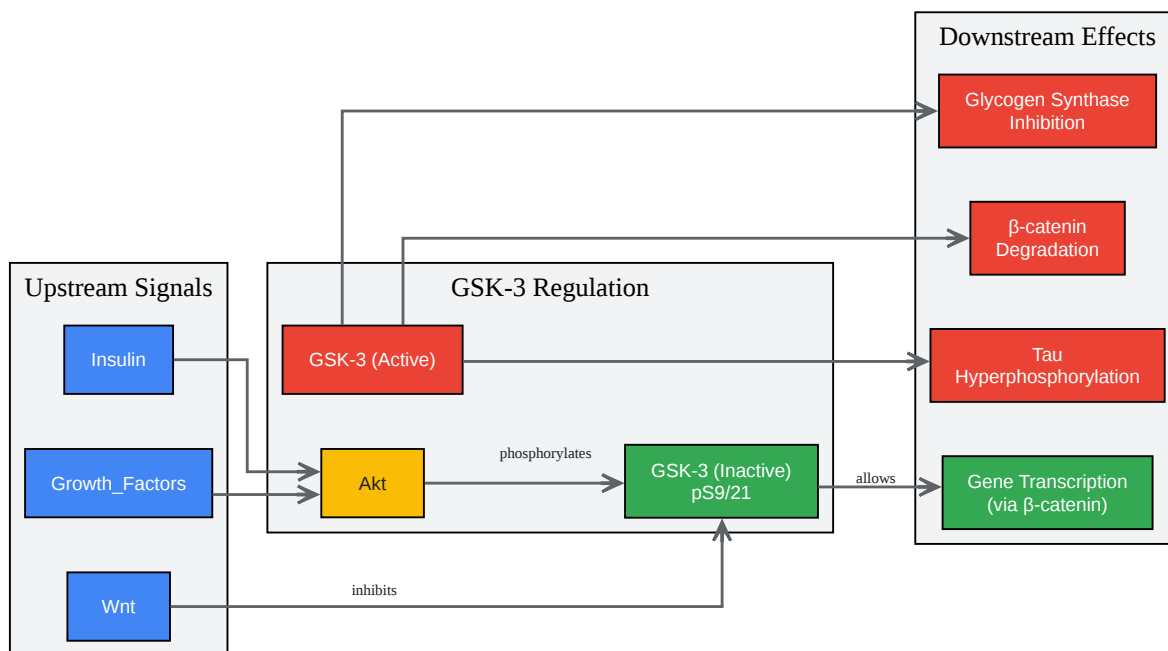

[Click to download full resolution via product page](#)

Caption: Overview of the GSK-3 signaling pathway.

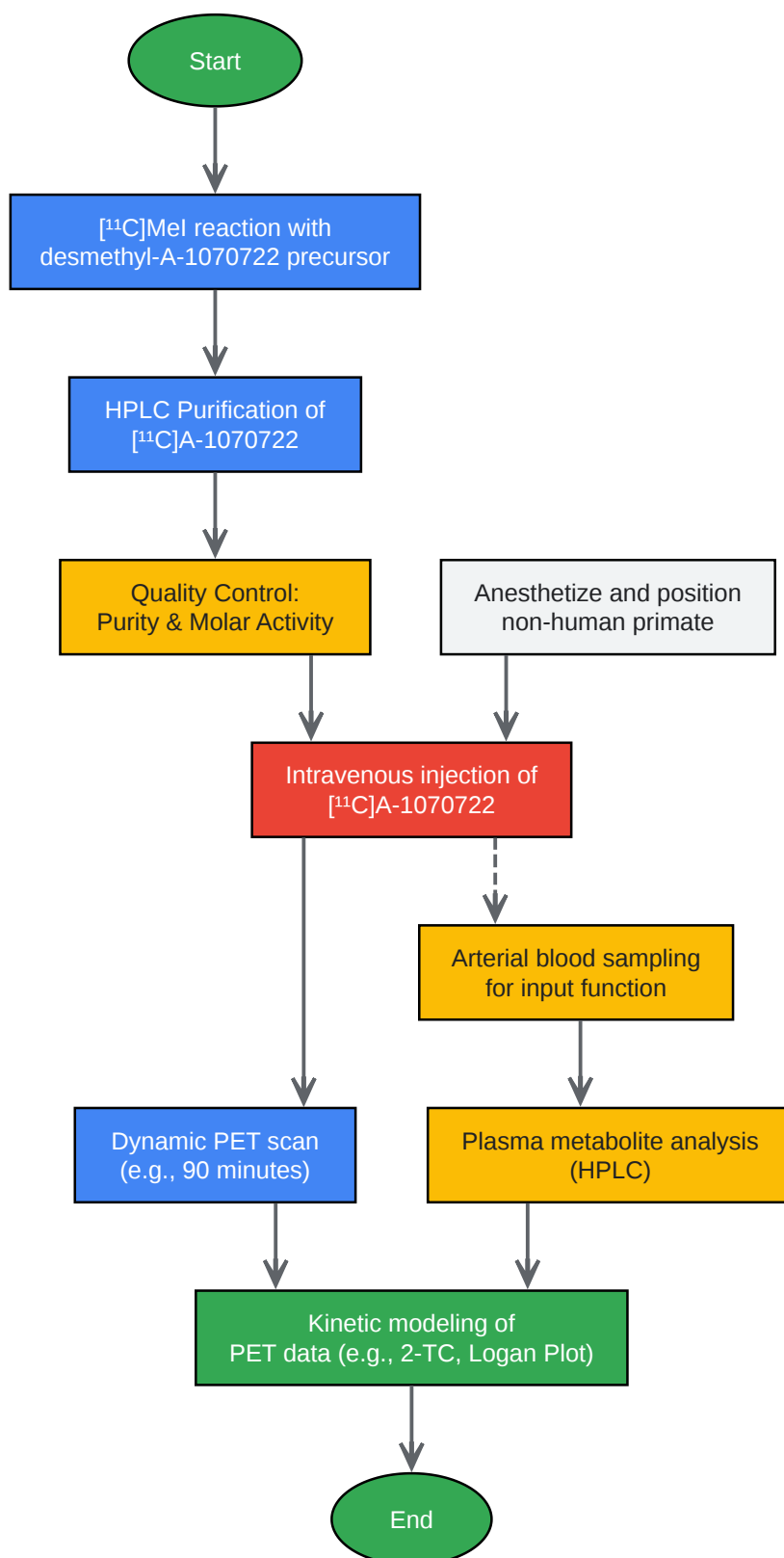

[Click to download full resolution via product page](#)

Caption: Experimental workflow for $[^{11}\text{C}]$ A-1070722 PET imaging.

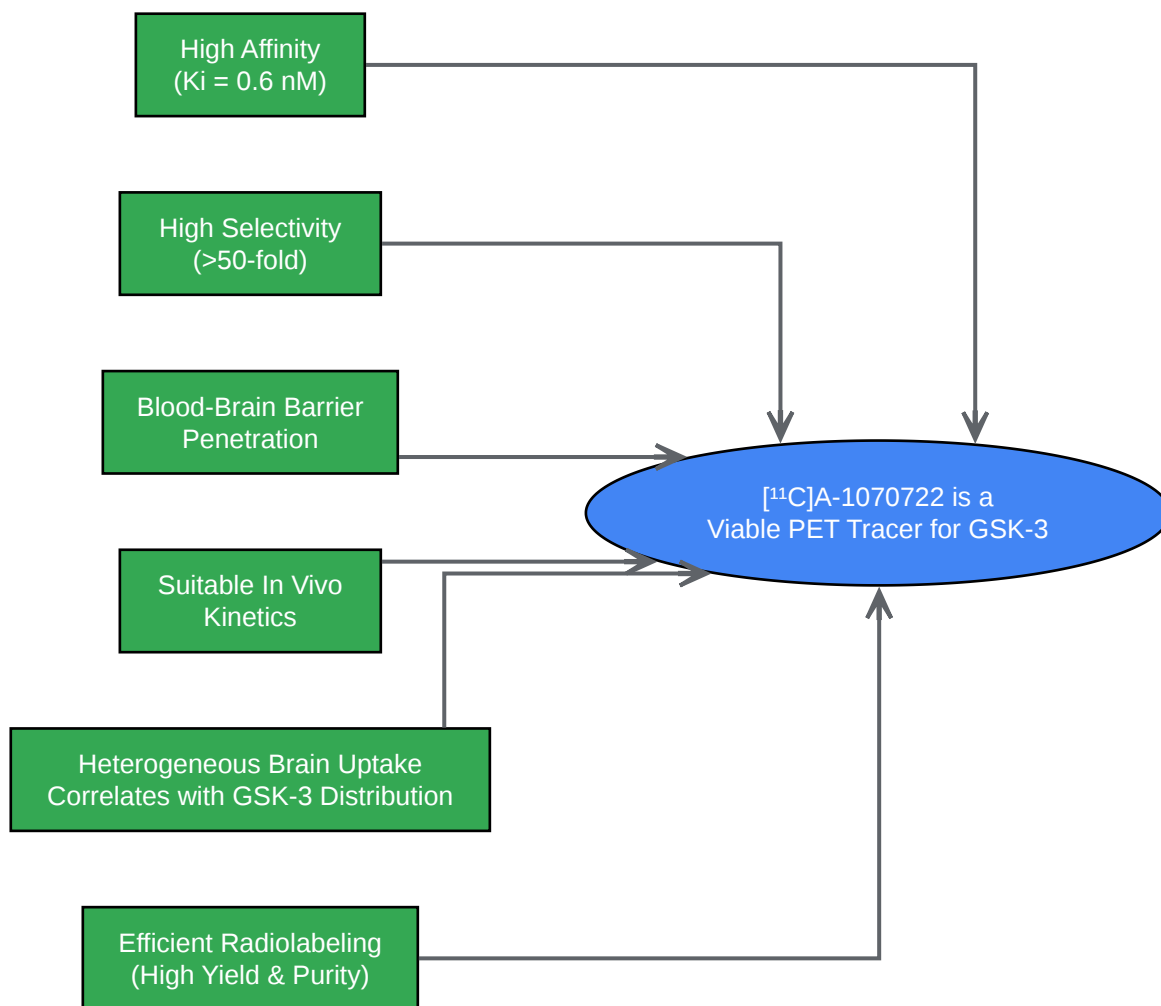

[Click to download full resolution via product page](#)

Caption: Validation logic for $[^{11}\text{C}]\text{A-1070722}$ as a PET tracer.

Experimental Protocols

Radiosynthesis of $[^{11}\text{C}]\text{A-1070722}$

This protocol is based on the method described by Prabhakaran et al.[1]

Materials:

- Desmethyl-A-1070722 precursor
- $[^{11}\text{C}]\text{Methyl iodide}$ ($[^{11}\text{C}]\text{MeI}$)

- Dimethylformamide (DMF)
- Sodium hydroxide (NaOH)
- HPLC system with a semi-preparative column
- Automated radiochemistry module (e.g., GE-FX2MeI/FX2M)

Procedure:

- Prepare a solution of the desmethyl-A-1070722 precursor in DMF.
- Add NaOH to the precursor solution to form the phenolate.
- Introduce [^{11}C]MeI into the reaction vessel containing the precursor solution.
- Allow the reaction to proceed at an elevated temperature within the automated radiochemistry module.
- Following the reaction, purify the crude product using a semi-preparative HPLC system to isolate [^{11}C]A-1070722.
- Formulate the purified [^{11}C]A-1070722 in a sterile solution suitable for intravenous injection.
- Perform quality control analysis to determine radiochemical purity, molar activity, and residual solvent levels.

In Vivo PET Imaging in Non-Human Primates

This protocol is a general guideline based on the study in vervet monkeys.^[1] All animal procedures should be approved by an Institutional Animal Care and Use Committee.

Materials:

- Anesthetized non-human primate (e.g., vervet or African green monkey)
- PET scanner
- [^{11}C]A-1070722 formulated for intravenous injection

- Anesthesia (e.g., isoflurane)
- Arterial line for blood sampling
- Centrifuge
- HPLC system for metabolite analysis

Procedure:

- Fast the animal overnight prior to the PET scan.
- Anesthetize the animal and maintain anesthesia throughout the imaging session.
- Position the animal in the PET scanner with the head in the field of view.
- Perform a transmission scan for attenuation correction.
- Administer a bolus intravenous injection of [¹¹C]A-1070722.
- Acquire a dynamic PET scan for a duration of, for example, 90 minutes.
- During the scan, collect arterial blood samples at predetermined time points.
- Process the blood samples to separate plasma.
- Analyze the plasma samples using HPLC to determine the fraction of unmetabolized parent radiotracer over time.
- Reconstruct the PET data and co-register with an anatomical MRI if available.
- Perform kinetic modeling of the time-activity curves from various brain regions using the metabolite-corrected arterial input function to calculate the total distribution volume (V_t).

Discussion

[¹¹C]A-1070722 has demonstrated the necessary characteristics of a promising PET tracer for imaging GSK-3 in the brain.[1] It exhibits high affinity and selectivity for its target, penetrates the blood-brain barrier, and shows a regional brain distribution consistent with the known

expression of GSK-3.[1][2][3] However, it is important to note that the total distribution volume (V_t) values are relatively low compared to other established neuroreceptor tracers, which may be due to the lower concentration of GSK-3 in the normative primate brain.[1] Further studies in animal models with potentially higher GSK-3 expression may be beneficial to further validate its utility.[1] The protocols and data presented here provide a solid foundation for researchers and drug development professionals to utilize [^{11}C]A-1070722 in their investigations of GSK-3 in neurological and psychiatric disorders.

Need Custom Synthesis?

BenchChem offers custom synthesis for rare earth carbides and specific isotopic labeling.

Email: info@benchchem.com or [Request Quote Online](#).

References

- 1. Radiosynthesis and in Vivo Evaluation of [^{11}C]A1070722, a High Affinity GSK-3 PET Tracer in Primate Brain - PMC [pmc.ncbi.nlm.nih.gov]
- 2. Radiosynthesis and in Vivo Evaluation of [^{11}C]A1070722, a High Affinity GSK-3 PET Tracer in Primate Brain. - National Genomics Data Center (CNGB-NGDC) [ngdc.cnbc.ac.cn]
- 3. pubs.acs.org [pubs.acs.org]
- 4. researchgate.net [researchgate.net]
- 5. Radiosynthesis and in Vivo Evaluation of [^{11}C]A1070722, a High Affinity GSK-3 PET Tracer in Primate Brain - PubMed [pubmed.ncbi.nlm.nih.gov]
- To cite this document: BenchChem. [A-1070722 for PET Imaging of Glycogen Synthase Kinase-3 (GSK-3)]. BenchChem, [2025]. [Online PDF]. Available at: [https://www.benchchem.com/product/b605029#a-1070722-for-pet-imaging-of-gsk-3]

Disclaimer & Data Validity:

The information provided in this document is for Research Use Only (RUO) and is strictly not intended for diagnostic or therapeutic procedures. While BenchChem strives to provide accurate protocols, we make no warranties, express or implied, regarding the fitness of this product for every specific experimental setup.

Technical Support: The protocols provided are for reference purposes. Unsure if this reagent suits your experiment? [[Contact our Ph.D. Support Team for a compatibility check](#)]

Need Industrial/Bulk Grade? [Request Custom Synthesis Quote](#)

BenchChem

Our mission is to be the trusted global source of essential and advanced chemicals, empowering scientists and researchers to drive progress in science and industry.

Contact

Address: 3281 E Guasti Rd

Ontario, CA 91761, United States

Phone: (601) 213-4426

Email: info@benchchem.com