

# 7-Amino-4-methylcoumarin assay interference from compounds

**Author:** BenchChem Technical Support Team. **Date:** December 2025

## Compound of Interest

Compound Name: Arnocoumarin

Cat. No.: B576994

[Get Quote](#)

Technical Support Center: Troubleshooting 7-Amino-4-methylcoumarin (AMC) Assay Interference

This guide is designed for researchers, scientists, and drug development professionals who utilize 7-Amino-4-methylcoumarin (AMC)-based assays. It provides detailed troubleshooting advice and protocols to identify and mitigate common sources of assay interference from test compounds.

## Frequently Asked Questions (FAQs)

Q1: What is the basic principle of an AMC-based assay?

AMC-based assays are widely used to measure enzyme activity, particularly for proteases and deubiquitinases.<sup>[1]</sup> The substrate in these assays consists of a peptide or other molecule covalently linked to AMC. This linkage quenches the fluorescence of the AMC molecule.<sup>[1][2]</sup> When the enzyme of interest cleaves the substrate, free AMC is released.<sup>[1][2]</sup> This free AMC is highly fluorescent, and the increase in fluorescence intensity, typically measured at an excitation wavelength of 340-380 nm and an emission wavelength of 440-460 nm, is directly proportional to the enzyme's activity.

Q2: What are the primary sources of compound interference in AMC assays?

Compound interference can lead to false-positive or false-negative results and generally falls into three main categories:

- **Compound Autofluorescence:** The test compound itself is fluorescent at the same wavelengths used to detect AMC, leading to a false-positive signal (apparent enzyme activation or reduced inhibition).
- **Fluorescence Quenching:** The test compound absorbs the excitation light or the emitted light from AMC, or it interacts directly with AMC to dissipate its energy through non-fluorescent means. This leads to a false-negative signal (apparent enzyme inhibition).
- **Direct Enzyme Inhibition/Activation:** The compound is a true inhibitor or activator of the enzyme, which is the desired outcome of the screen. Distinguishing this from artifacts is crucial.

Q3: What are Pan-Assay Interference Compounds (PAINS)?

PAINS are chemical compounds that frequently produce false-positive results in high-throughput screening assays. They tend to interact non-specifically with numerous biological targets or interfere with assay technologies through various mechanisms like redox activity, aggregation, or covalent protein modification. Common PAINS substructures include catechols, quinones, rhodanines, and enones. Identifying potential PAINS early can save significant time and resources.

## Troubleshooting Guide: Symptom-Based Problem Solving

This section addresses common unexpected results and provides a systematic approach to identify the root cause.

### **Problem 1: High background fluorescence in my control wells (e.g., "no enzyme" or wells with compound alone).**

A high background signal can mask the true enzymatic signal, reducing the assay's sensitivity and dynamic range.

Possible Causes & Solutions:

Possible Cause	How to Investigate	Solution(s)
Test Compound Autofluorescence	Run a "no-substrate" control containing your test compound and all other assay components except the AMC-substrate.	If the compound is autofluorescent, subtract its signal from the experimental wells. If the signal is too high, consider using a fluorophore with a red-shifted spectrum (e.g., Rhodamine 110) to minimize overlap.
Substrate Autohydrolysis	Incubate the AMC-substrate in the assay buffer without any enzyme and measure fluorescence over time.	If the signal increases, the substrate is unstable. Prepare the substrate solution fresh before each use, adjust buffer pH, or test alternative buffer conditions.
Contaminated Reagents/Buffer	Test each assay component (buffer, water, DMSO) individually for fluorescence at the assay wavelengths.	Use high-purity reagents and freshly prepared buffers. For cell-based assays, use phenol red-free medium.

## Problem 2: The fluorescence signal is lower than expected or shows false inhibition.

A decrease in fluorescence that is not due to true enzyme inhibition can lead to the misinterpretation of a compound as an inhibitor.

Possible Causes & Solutions:

Possible Cause	How to Investigate	Solution(s)
Fluorescence Quenching	Perform a quenching counter-assay. Add the test compound to a solution of free AMC (at a concentration similar to that produced in the assay) and measure the fluorescence. A decrease in signal indicates quenching.	If quenching is observed, the compound is a false positive. Consider orthogonal assays with different detection methods (e.g., colorimetric, luminescent) to confirm activity.
Inner Filter Effect	Measure the absorbance spectrum of the test compound.	If the compound's absorbance overlaps with the AMC excitation (~350-380 nm) or emission (~440-460 nm) wavelengths, it can block light from reaching or leaving the sample. Consider lowering the compound concentration or using a different assay format.
Compound Precipitation	Visually inspect the wells of the assay plate for any signs of precipitation (cloudiness, particles).	If precipitation occurs, lower the final compound concentration or adjust the solvent (e.g., DMSO) concentration, ensuring it does not inhibit the enzyme. Including a small amount of a non-ionic detergent like Triton X-100 can sometimes prevent aggregation.
Enzyme Inactivity	Run a positive control with a known active enzyme or a known inhibitor to ensure the assay is performing correctly.	Ensure the enzyme is stored properly and has not undergone multiple freeze-thaw cycles. Prepare fresh enzyme dilutions for each experiment.

## Experimental Protocols

### Protocol 1: Testing for Compound Autofluorescence

Objective: To determine if a test compound emits fluorescence at the AMC assay wavelengths.

Methodology:

- **Plate Setup:** In a black, opaque microplate, prepare wells containing the assay buffer and the test compound at its final screening concentration.
- **Controls:** Include wells with assay buffer and the compound vehicle (e.g., DMSO) as a blank control.
- **Measurement:** Read the fluorescence of the plate using the same excitation and emission wavelengths as your main assay (e.g., Ex: 380 nm, Em: 460 nm).
- **Analysis:** Subtract the average fluorescence of the vehicle control wells from the fluorescence of the compound-containing wells. A significant net increase in fluorescence indicates autofluorescence.

### Protocol 2: Counter-Assay for Fluorescence Quenching

Objective: To determine if a test compound quenches the fluorescence of free AMC.

Methodology:

- **Plate Setup:** In a black, opaque microplate, add a solution of free AMC in assay buffer to all wells. The concentration of AMC should be comparable to the amount of product generated in the positive control of the primary assay.
- **Add Compound:** Add the test compound at its final screening concentration to the experimental wells. Add the compound vehicle (e.g., DMSO) to control wells.
- **Measurement:** Read the fluorescence of the plate immediately.
- **Analysis:** Compare the fluorescence signal of wells containing the test compound to the vehicle control wells. A significant decrease in fluorescence indicates that the compound is a quencher.

## Protocol 3: AMC Standard Curve

Objective: To convert relative fluorescence units (RFU) to the molar concentration of the product formed.

Methodology:

- **Stock Solution:** Prepare a 1 mM stock solution of free AMC in DMSO. Store at -20°C, protected from light.
- **Serial Dilutions:** Create a series of dilutions of the AMC stock solution in the assay buffer, ranging from a high concentration down to zero (buffer only blank).
- **Measurement:** Add the dilutions to a microplate and read the fluorescence using the standard assay settings.
- **Plotting:** Subtract the blank reading from all measurements. Plot the background-corrected RFU values against the known AMC concentrations to generate a standard curve.

## Visualizing Interference and Troubleshooting

The following diagrams illustrate the mechanisms of interference and the workflow for identifying false positives.

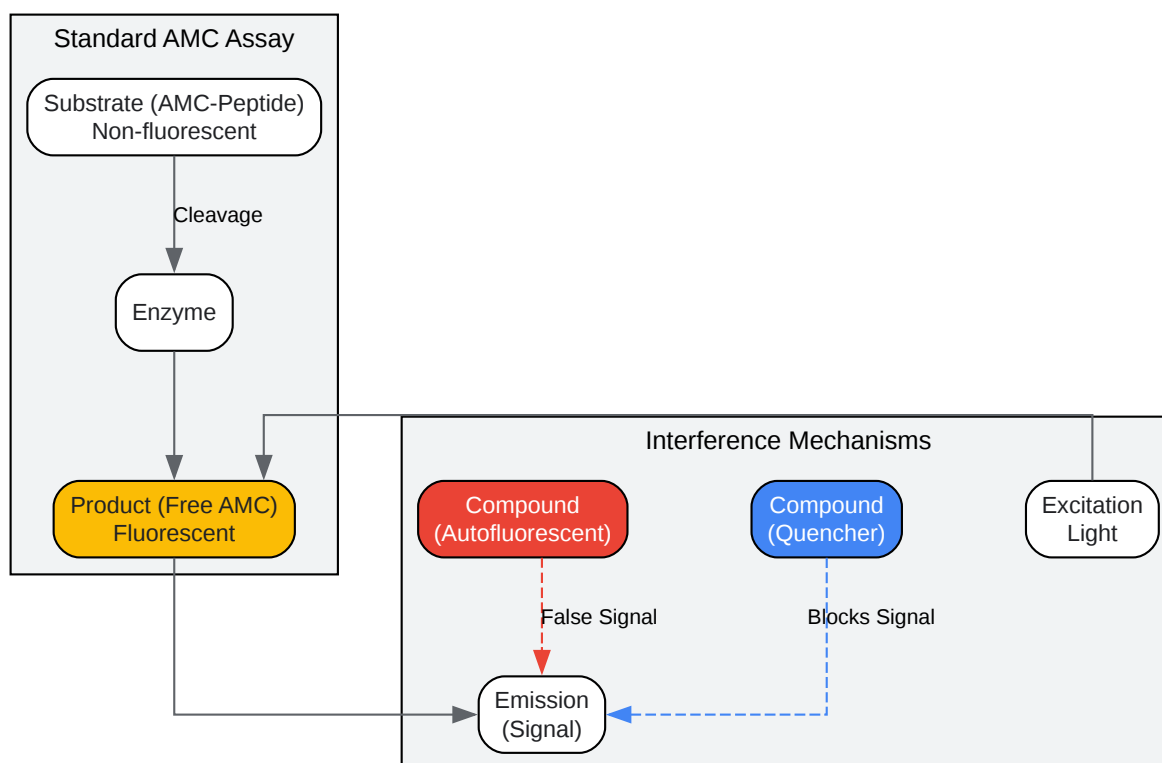

[Click to download full resolution via product page](#)

**Caption:** Mechanisms of AMC Assay Interference. (Within 100 characters)

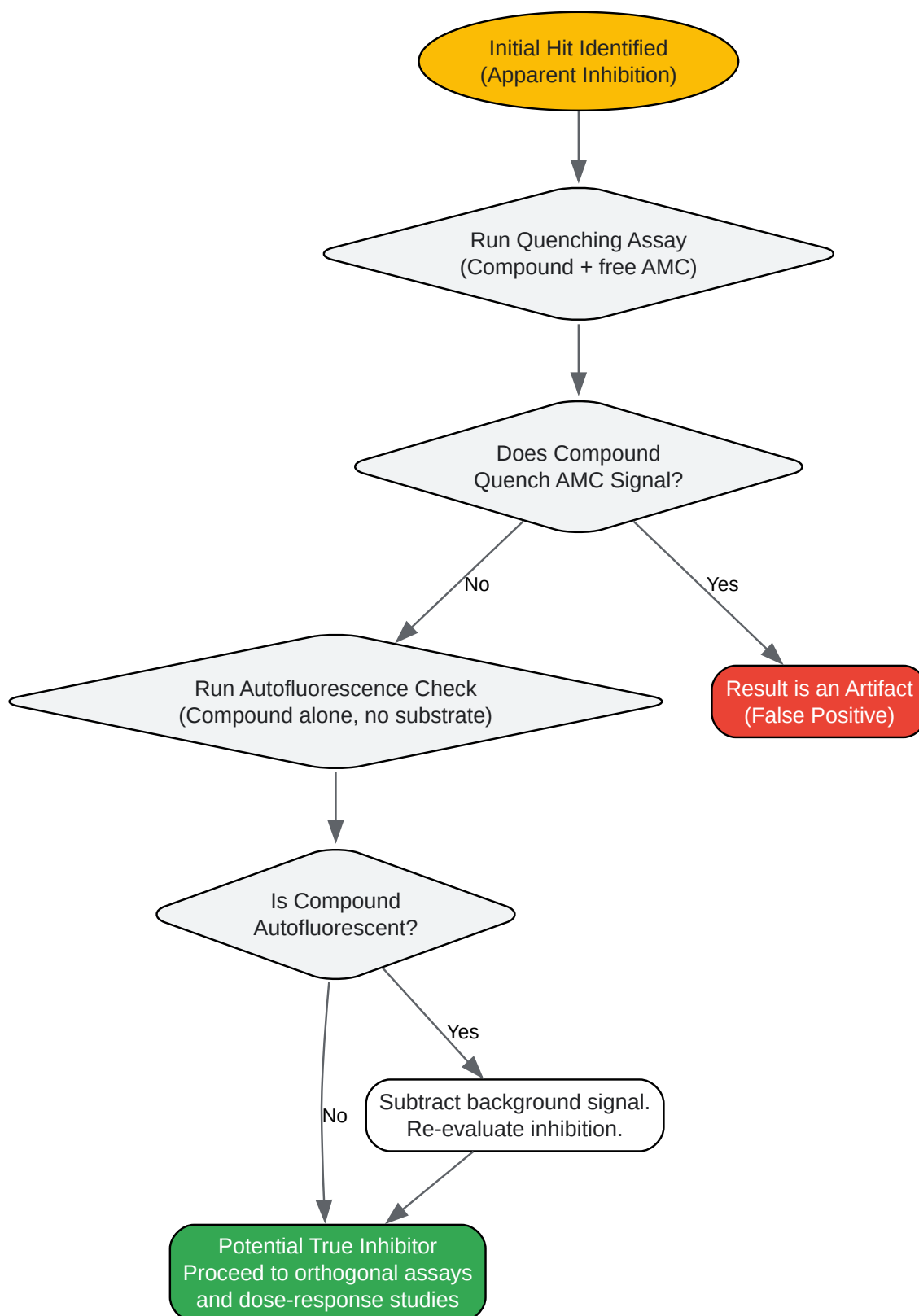

[Click to download full resolution via product page](#)

**Caption:** Workflow for Investigating False Positives. (Within 100 characters)



### Need Custom Synthesis?

BenchChem offers custom synthesis for rare earth carbides and specific isotopic labeling.

Email: [info@benchchem.com](mailto:info@benchchem.com) or [Request Quote Online](#).

## References

- 1. Assay Systems for Profiling Deubiquitinating Activity [mdpi.com]
- 2. researchgate.net [researchgate.net]
- To cite this document: BenchChem. [7-Amino-4-methylcoumarin assay interference from compounds]. BenchChem, [2025]. [Online PDF]. Available at: [https://www.benchchem.com/product/b576994#7-amino-4-methylcoumarin-assay-interference-from-compounds]

### Disclaimer & Data Validity:

The information provided in this document is for Research Use Only (RUO) and is strictly not intended for diagnostic or therapeutic procedures. While BenchChem strives to provide accurate protocols, we make no warranties, express or implied, regarding the fitness of this product for every specific experimental setup.

**Technical Support:** The protocols provided are for reference purposes. Unsure if this reagent suits your experiment? [[Contact our Ph.D. Support Team for a compatibility check](#)]

**Need Industrial/Bulk Grade?** [Request Custom Synthesis Quote](#)

## BenchChem

Our mission is to be the trusted global source of essential and advanced chemicals, empowering scientists and researchers to drive progress in science and industry.

### Contact

Address: 3281 E Guasti Rd  
Ontario, CA 91761, United States  
Phone: (601) 213-4426  
Email: [info@benchchem.com](mailto:info@benchchem.com)